

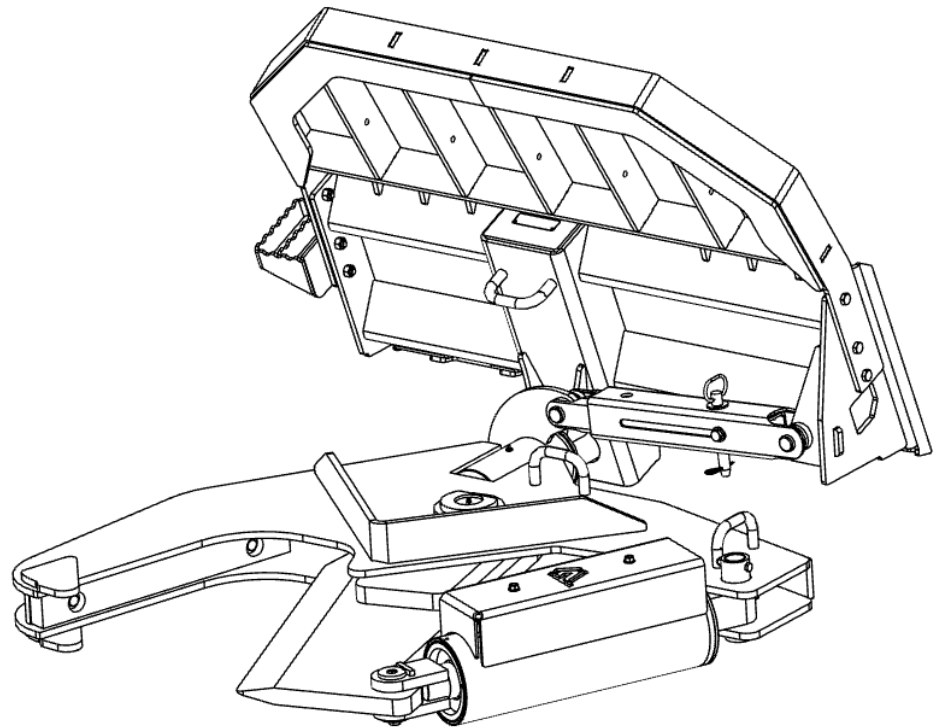

# QUICK ATTACH



**POWER AXE™**  
**TREE SHEAR**  
**Operator's Manual**  
**Maintenance & Parts Information**



**Read this Manual Before Use**

---

SAFETY	3-4
DECAL INFORMATION	5-6
SETUP ASSEMBLY	7-8
MOUNTING INSTRUCTIONS	9-10
OPERATING INSTRUCTIONS	11-15
MAINTENANCE	16-17
PARTS INFORMATION	18-24
GENERAL SPECS	25
TORQUE INFORMATION	26
WARRANTY	27

**NOTE:** Write your serial number for your attachment in the spaces below. Always refer to this serial number when calling for services parts.

---

**Serial Number**

---

**Attachment Dealer**

---

**Address**

---

**Phone Number**

---

**Contact**

**NOTE:** Quick Attach LLC reserves the right to make improvements in design or changes in specifications at any time without notice and without incurring any obligations to install them on units previously sold.

---

**DO NOT use or perform maintenance on this machine until this manual has been read and understood. In addition, read the Operation and Maintenance Manual(s) pertaining to the attachment and the attachment carrier (“Loader”).**

The user is responsible for inspecting the machine daily, and for having parts repaired or replaced when continued use of the machine would cause damage, excessive wear to other parts or make the machine unsafe for continued operation.

If an operating procedure, tool device, maintenance or work method not specifically recommended is used; you must satisfy yourself that it is safe for you and others. You must also ensure that the attachment will not be damaged or made unsafe by the procedures you choose.

Quick Attach LLC cannot anticipate every possible circumstance that might involve potential hazard. The safety messages found in this manual and on the machine are therefore not all inclusive.

The signal words **CAUTION**, **WARNING**, or **DANGER** are used to indicate hazards.

**⚠ CAUTION**

Indicates a potentially hazardous situation which, if not avoided, may result in minor or moderate injury.

**⚠ WARNING**

Indicates a potentially hazardous situation which, if not avoided, could result in death or serious injury.

**⚠ DANGER**

Indicates a potentially hazardous situation which, if not avoided, will result in death or serious injury.

The word **IMPORTANT** is used in the text when immediate damage will occur due to improper technique or operation.

The word **NOTE** is used to convey information that is out of context with the manual text; special information such as specifications, techniques, reference information, and other information of a supplementary nature.

# SAFETY

---

## Improper operation can cause serious injury or death.

### PRE-OPERATION

- **NEVER** use this attachment for purposes other than intended.
- Read the operator's manual for the "Skid Steer Loader". **NEVER** allow untrained people to operate.
- Operating instructions must be given to everyone before operating this machine and at least once a year thereafter in accordance with OSHA regulations.
- **NEVER** exceed the maximum recommended input power or speed specifications for the attachment. Over-powering or over-speeding the attachment may cause personal injury and/or machine damage.
- Keep all shields, guards, and covers in place.
- Do not modify equipment or add attachments that are not approved by Quick Attach LLC.
- Use adequate safety warning lights and devices as required by local regulations. Obey all local laws and regulations regarding machine operation on public property.

### OPERATION

- Always wear eye protection that meets z87.1 or use with a loader enclosure that provides similar protection.
- Hydraulic connections may be hot after use. Use gloves if connecting or disconnecting after use.
- Check and be sure all operating controls are in neutral before starting the engine.
- Keep people away from loader, attachment and discharge when in use. This attachment sends objects flying and has rotating parts. **NEVER** direct discharge toward people – rocks and debris can be thrown.

### OPERATION (continued)

- **NEVER** operate near embankments or terrain that is so steep that rollover could occur.
- Always stay in the operator position when using the attachment.
- Before leaving the operators position, disengage hydraulic drive, lower the attachment to rest flat on the ground, stop engine, set park brake, and wait for all motion to stop.
- **NEVER** place hands in the discharge chute or clear debris while engine is running.

### AVOID HIGH PRESSURE FLUIDS HAZARD

- Escaping fluid under pressure can penetrate the skin causing serious injury.
- Avoid the hazard by relieving the pressure before disconnecting hydraulic lines.
- Use a piece of paper or cardboard, **NOT BODY PARTS**, to check for suspected leaks. Wear protective gloves and safety glasses or goggles when servicing or performing maintenance on hydraulic systems.
- If an accident occurs, see a doctor immediately. Any fluid injected into the skin must be surgically removed within a few hours or gangrene may result.

### MAINTENANCE

- **NEVER** make adjustments, lubricate, clean, or perform any service on the machine while it is in operation.
- Make sure the attachment is serviced on a daily basis. Improper maintenance can cause serious injury or death in addition to damage to the attachment and/or your equipment.

# DECAL INFORMATION

## Serial Number Location:

It is important to refer to the serial number of your attachment when making repairs or ordering parts. Early or later models (identification made by serial number) may use different parts, or it may be necessary to use different procedures in doing a specific operation. Please see below for Serial Plate location.

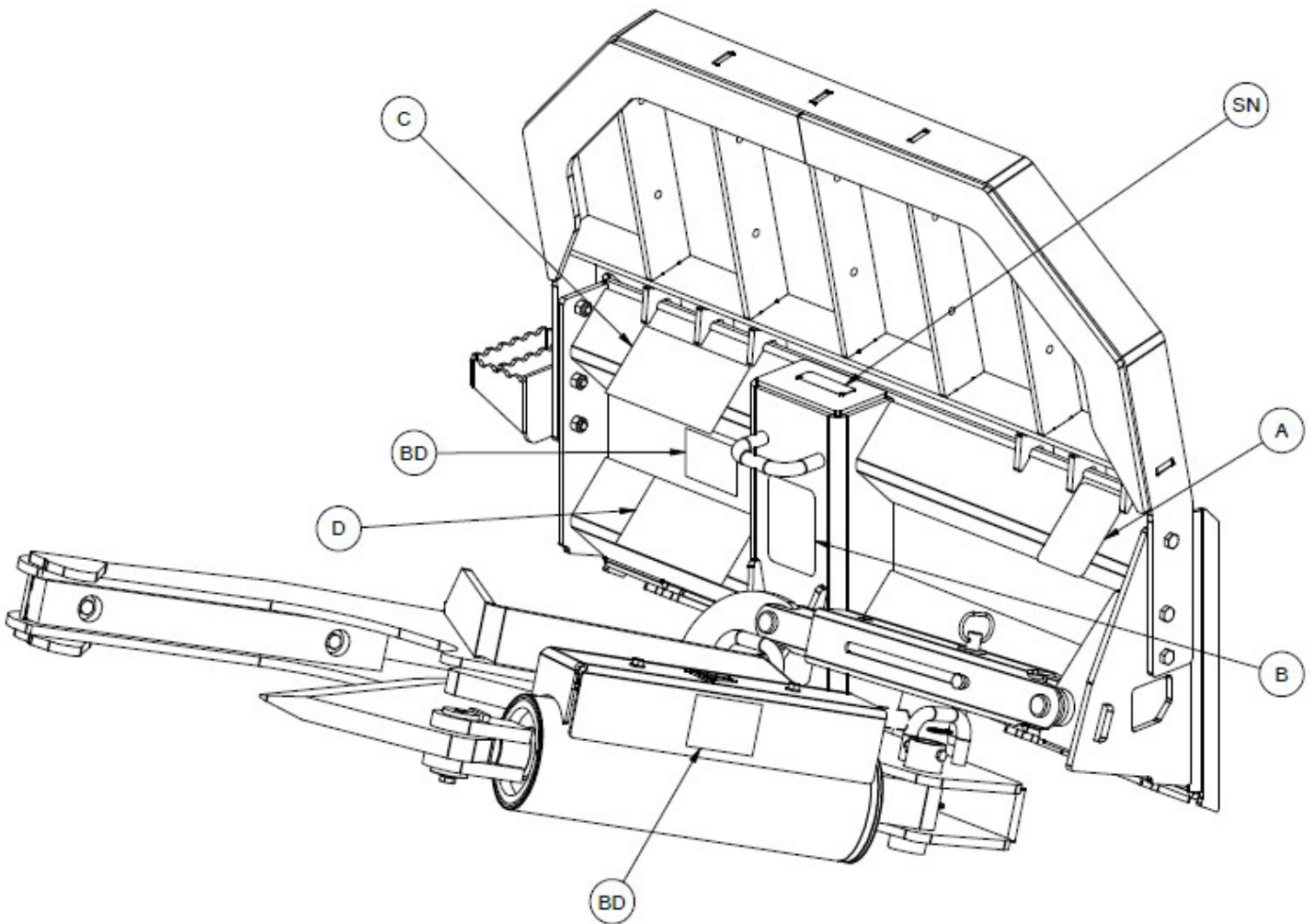

# DECAL INFORMATION



Part number: 200001  
 Location: On LH front of mount frame, outer  
 Quantity: 1



Part number: 203234  
 Location: On LH front of mount frame, inner  
 Quantity: 1



Part number: 316795  
 Location: On RH front of mount frame, upper  
 Quantity: 1

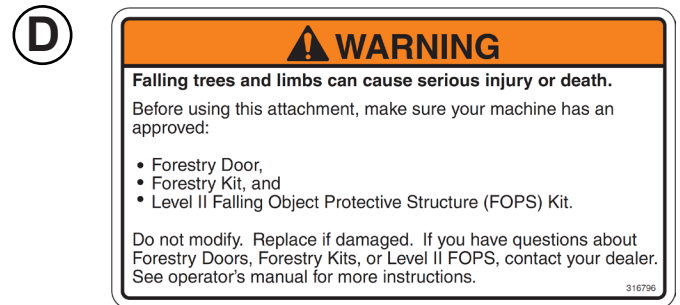

Part number: 316796  
 Location: On RH front of mount frame, lower  
 Quantity: 1



Brand Decal: Mini (332279)  
 Location: (1) Side of cylinder shield  
 (1) RH front mount frame, center  
 Quantity: 2

## Safety Decals Locations:

The locations of the safety decals are shown. If these decals are missing, damaged, or painted over they must be replaced. Call Quick Attach LLC (320-759-1551) for replacement decals.

# SETUP ASSEMBLY

## Wire Harness Installation

If the soil conditioner was ordered with the hydraulic angling package, a wire harness is required to activate the angling feature. If the loader is equipped with an attachment control package, an appropriate harness should be installed from the factory.

If the attachment was ordered with the pistol grip control harness, use the following steps to install the harness on the loader:

1. Install the control handle on either steering lever, whichever you prefer, with (2) hose clamps.

**NOTE:** The control handle bracket can be positioned several different ways. The recommended position is shown.

2. Put a cable tie around the wiring harness and the steering lever.
3. Install the wire harness receptacle bracket on the loader arm or near the hydraulic quick couplers.

**NOTE:** It may be necessary to make an adapter bracket in order to attach the wire harness to the loader.

4. Route the wiring harness back along the tube lines on the loader arms and fasten with cable ties.
5. Open the rear door and pull the excess wiring into the engine compartment.
6. Raise the operator cab (see loader's operator's manual for the correct procedure).

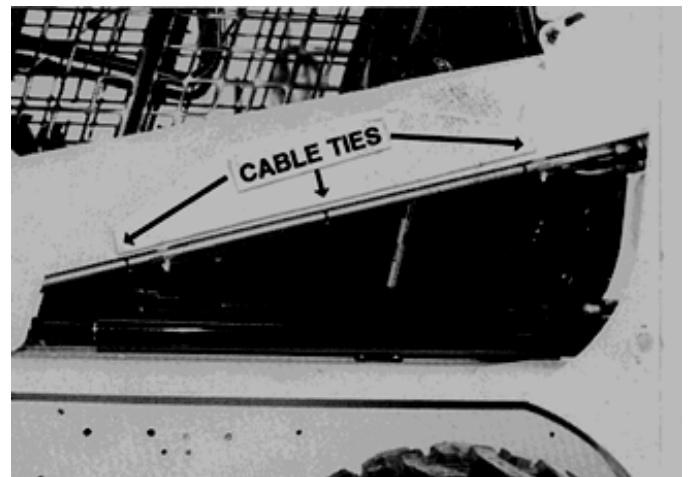

# SETUP ASSEMBLY

---

7. Connect the red fused wire to the positive battery terminal or to a suitable accessory wire with a minimum rating of 5 amps. Route the wiring along the loader main frame toward the front of the loader.
8. Fasten the control handle wiring harness connector to the main wiring harness connector.

**IMPORTANT:** Secure the wiring harness in place with plastic cable ties, making sure it is clear of extra hot areas or any moving parts on the engine or loader. Pinched, stretched, or melted wire harnesses are not covered under warranty.

9. Lower the cab (see loader's operator's manual for the correct procedure).

**NOTE:** Be sure the control handle wire harness is properly positioned as the cab is lowered.

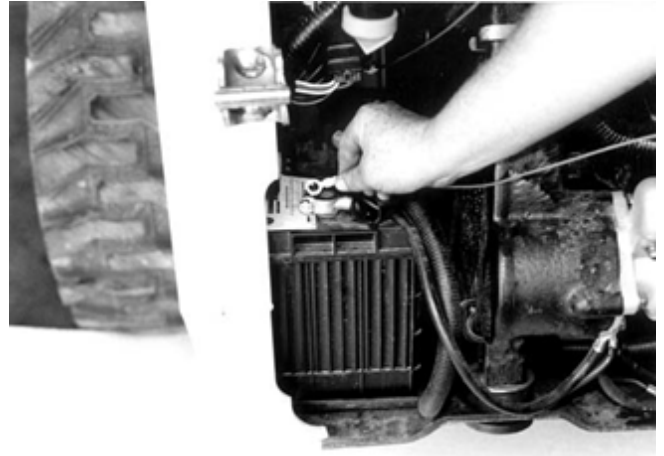

# MOUNTING INSTRUCTIONS

After the initial set-up assembly is completed use the following procedure to mount the attachment to the loader for user operation.

## **⚠ WARNING**

**Coupler wedges or pins must extend through holes in attachment. Levers must be fully down and locked. Failure to secure wedges or pins can allow the attachment to come off and cause injury or death.**

1. Use the step, safety treads, and grab handles to get on and off the loader and attachment.
2. Sitting in the operator's seat, lower seat bar (if so equipped) and fasten the seat belt.
3. Drive the loader to the rear of the attachment. Put the loader quick attach coupler into the attachment mounting bracket.
4. Tilt the loader coupler backward a small amount until it is fully engaged in the attachment mounting bracket.
5. Stop the engine and engage the park brake.
6. Secure the coupler locking mechanism that attaches the attachment to the loader.
7. Connect the hydraulic quick couplers from the attachment to the loader.

**IMPORTANT:** Wipe the ends of the hydraulic quick couplers (both lead and loader) with a rag to remove any possible contamination. Contamination can cause hydraulic components to fail and is not covered under warranty.

**IMPORTANT:** Make sure the quick couplers are fully engaged. If the quick couplers do not fully engage, check to see that the couplers are the same size and brand. Do not force the quick couplers together.

**NOTE:** See the loader's operator's manual for auxiliary hydraulic specifications and connection instructions.



# MOUNTING INSTRUCTIONS

---

**NOTE:** Attachment is shipped with 8FJX (1/2" Female JIC Swivel) fittings on the ends of the lead hoses.

8. Make sure the hoses are properly routed to fit your specific loader. If the hoses are not routed correctly, hoses may get pinched or rub on tires. Be sure to check the hose routing through the full range of intended motion of the attachment before operating it.

**NOTE:** More than one routing may be acceptable depending on the loader. Pick the routing that best suits your loader.

**IMPORTANT:** Proper hose routing is the responsibility of the owner and/or operator. Pinched or stretched hoses are not covered under warranty.

**NOTE:** Mounting is now complete and the attachment is ready for operation. Use reverse order of above instructions to dismount the attachment from the loader.



# OPERATING INSTRUCTIONS

## Felling a Tree (Blade in Horizontal Position)

**⚠ WARNING** To avoid serious injury or death, keep people away from loader and attachment when in use. The attachment can drop trees and limbs in unpredictable directions. Make sure there are no people, power lines, buildings, or other objects that could be in the fell zone. **NEVER** cut trees that could fall onto these objects.

**⚠ WARNING** To avoid electric shock or electrocution, never operate the attachment near overhead power lines.

1. Select a tree 14" in diameter or less.

**⚠ WARNING** To avoid injury or death, never shear a tree larger than 14" in diameter.

2. With the operator in the loader seat, seat belt fastened and seat bar lowered (if so equipped), start the engine.
3. Position the loader behind the tree so that the fell zone is to the right of the loader. While the attachment wedge pushes trees 90 degrees to the right of the cab, tree felling can be unpredictable. Consider factors like: lean of the tree, contact with other trees, bend, wind direction, branch arrangement, and snow.

4. Approach tree with the loader arms within 2 feet of the ground.

**⚠ WARNING** To avoid tipping, never shear more than 2 feet above the ground when felling a tree.

5. Open the blade on the attachment. Drive the loader forward to position the tree between the blade and the jaw.



6. Activate the hydraulics on the loader to close the blade on the attachment to shear the tree.
7. After tree has been fully sheared and has fallen to the ground, open the blade and back the loader away from the tree stump.
8. Always keep the attachment in a low position when moving from tree to tree.

# OPERATING INSTRUCTIONS

## Changing Blade from Horizontal to Vertical (Felling to Limbing)

1. Raise the loader's arms up enough for the blade/jaw assembly to be turned to the vertical position
2. Close the blade on the shear.

**⚠ WARNING** To avoid serious injury or death, NEVER change blade direction with the blade open on the shear.

3. Shut down the engine of the loader, set the parking brake, and exit the cab.
4. Remove the pin from the adjustable arm assembly.
5. Grab hold of handle [A] and lift. Rotate until blade/jaw assembly is in the fully vertical position.
6. Install the pin into the adjustable arm assembly to lock the blade/jaw assembly into the vertical position.

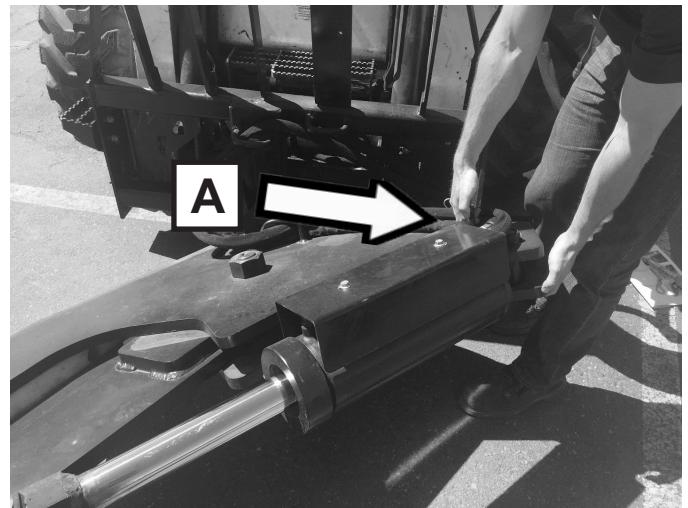

# OPERATING INSTRUCTIONS

## Limbing a Tree (Blade in Vertical Position)

**⚠ WARNING** This attachment may not allow you to control the falling direction of limbs. Make sure there are no people, power lines, buildings, or other objects that could be in the fall zone. NEVER cut limbs that could fall onto these objects.

**⚠ WARNING** To avoid electric shock or electrocution, never operate the Tree Shear near overhead power lines.



1. Select a limb 14" in diameter or less

**⚠ WARNING** To avoid injury or death, never shear a tree larger than 14" in diameter.

2. With the operator in the loader seat, seat belt fastened and seat bar lowered (if so equipped), start the engine.
3. With the attachment in the vertical position, drive the loader up to the tree.
4. Open the blade on the attachment. Drive the loader forward to position the tree limb between the blade and the jaw.
5. Activate the hydraulics on the loader to close the blade on the attachment to shear the tree limb.
6. After the tree limb has been fully sheared and has fallen to the ground, open the blade and back the loader away from the tree.
7. Always keep the attachment in a low position when moving from tree to tree.



# OPERATING INSTRUCTIONS

## Cutting Trees to Size

1. With the attachment in the vertical position, drive the loader perpendicular to the fallen tree.

**⚠ WARNING** To avoid injury or death, never shear a tree larger than 14" in diameter.

2. Open the blade on the attachment. Drive the loader forward to position the tree between the blade and the jaw.
3. Activate the hydraulics on the loader to close the blade on the attachment to shear the tree.
4. After the tree limb has been fully sheared, open the blade and back the loader away from the tree. Reposition the loader and make other cuts as necessary.



# OPERATING INSTRUCTIONS

## Hydraulic Tilt Function

A tree shear with the hydraulic rotate option installed is equipped with an electrically actuated diverter valve. The valve can send oil to one of two paths. The primary (default) path is to the hydraulic cylinder that moves the blade. The secondary path is to the tilt cylinder.

**IMPORTANT:** Skid Steer Loader controls vary from machine to machine. Read the loader's operating instructions to become familiar with the loader control functions. Certain loaders may require a special harness jumper wire to operate correctly.

### To Operate Tilt:

1. Stop auxiliary hydraulic flow.
2. **Push and HOLD** the button that energizes the diverter valve. (usually on left handle)
3. Momentarily operate auxiliary hydraulic flow in forward or reverse direction to achieve desired tilt angle.
4. De-energize the diverter valve.
5. Resume normal operation.

**IMPORTANT:** Do not attempt to tilt while cutting a tree. Always stop hydraulic flow before operating tilt function.



**PUSH AND HOLD TO ENERGIZE DIVERTER**



**PUSH AND HOLD TO ENERGIZE DIVERTER  
(OPTIONAL PISTOL GRIP HARNESS SHOWN)**



**OPERATE AUXILIARY HYDRAULICS TO TILT**

# ROUTINE MAINTENANCE





## **⚠ WARNING**

Lower the attachment to rest flat on the ground, shut down the engine, relieve the hydraulic pressure to the attachment, set the park brake, and wait for all motion to stop before leaving the operator's seat to perform service of any kind.



It is the operator's responsibility to make daily inspections of the loader and attachment for damage, loose bolts, fluid leaks, or anything else that could cause a potential service or safety problem. Preventive maintenance is the easiest and least expensive type of maintenance.

**IMPORTANT:** Bolts can loosen after initial usage. After the first hour of operation check all bolts.

## LUBRICATION

<b>Lubrication Legend</b>	 Multipurpose spray lube	 Multipurpose grease lube	 Multipurpose oil lube	 Intervals at which lubrication is required
---------------------------	---	--	--	--

Use No. 2 lithium base gun grease when lubricating all attachment grease fittings.

	
--	--

Grease the Jaw Pivot Point zerk (A) every 4 hours of operation.

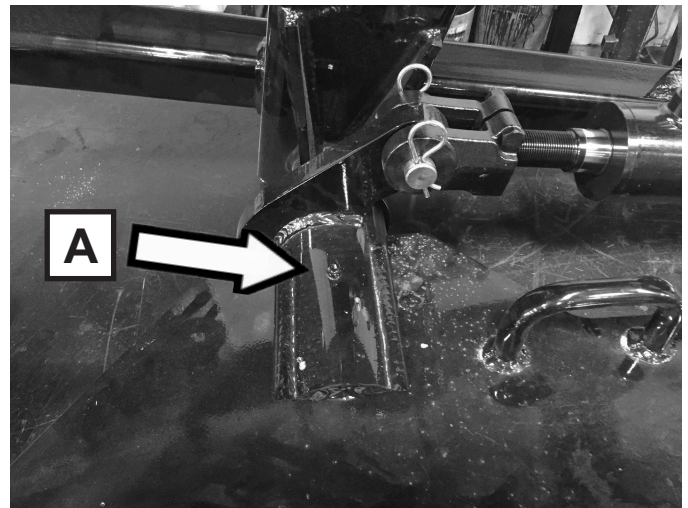

Grease the Blade Pivot Pin zerk (B) every 4 hours of operation.

**IMPORTANT:** It is the responsibility of the owner/operator to make sure the attachment is serviced on a daily basis. Improper maintenance can cause extensive damage to the attachment and/or your equipment.



# ROUTINE MAINTENANCE

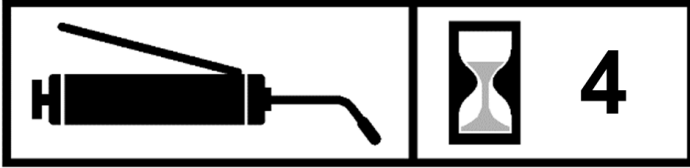

Grease the Cylinder Base Bushing zerk [A] every 4 hours.

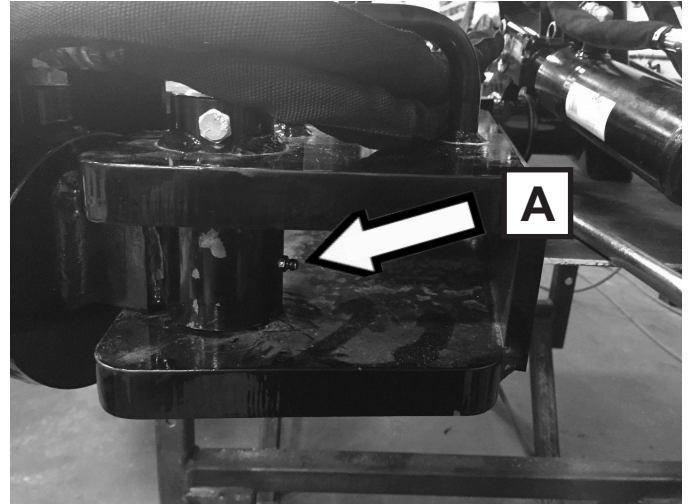

Grease the Cylinder Rod Pin zerk [B] every 4 hours of operation.

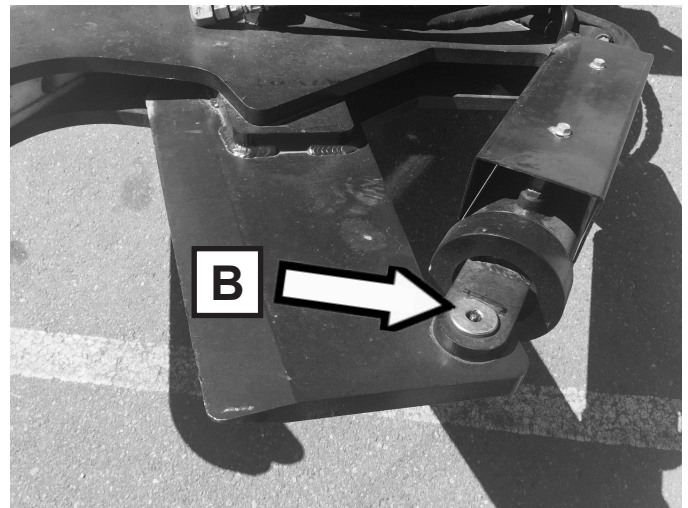

# PARTS INFORMATION

ITEM	QTY	PART NUMBER	DESCRIPTION	STOCK NO.
1	1	13113	BOLT HEX 3/8 X 2.5 GR5	
2	1	13207	BOLT HEX 1/2 X 1.25 GR5	Apply Thread Locking Compound
3	4	13209	BOLT HEX 1/2 X 1.5 GR5	
4	2	13210	BOLT HEX 1/2 X 1.75 GR5	
5	2	13213	BOLT HEX 1/2 X 2.5 GR5	
6	1	13218	BOLT HEX 1/2 X 3.75 GR5	Manual Rotate Only
7	1	13311	BOLT HEX 5/8 X 2 GR5	Apply Thread Locking Compound
8	1	13361	BOLT HEX 3/4 X 2 GR5	Apply Thread Locking Compound
9	2	19929	BOLT 3/8 X 3/4 NC FLG	
11	1	200064	PIN CLIP #11 1/8 X 2 5/8	Manual Rotate Only
15	1	300284	PIN HITCH 3/4 X 5	Manual Rotate Only
16	1	313243	WASHER PLATE .53 X 2.0 X .37 Z	
17	1	313277	BLADE TREE SHEAR W/A	
18	1	313295	PIN 1.50 X 5.875 Z W/H	
19	1	313298	PLASTIC BLADE STOP	
20	1	313299	FLAT .5 X 2.44 X 4.5 W/ H PNT	
21	1	316420	STEP BOLT ON W/A	
24	1	316725	CYLINDER 5.5 X 14 C-B	
25	1	316728	WASHER PLASTIC 3.06 X 5	
26	1	316731	BUSH 1.5 X .69 X .81 Z	
27	1	316732	PIN 1.5 X 2.81 MACHINED Z	
32	4	32467	BOLT THDCUT FLG 3/8 X 34 NC	Hydraulic Rotate Only
33	2	33012	WASHER FLAT USS 1/2	
34	2	33086	WASHER FLAT SAE 1/2	Manual Rotate Only
36	3	33626	WASHER SPLIT LOCK 1/2	
37	1	33630	WASHER SPLIT LOCK 5/8	
38	1	33632	WASHER SPLIT LOCK 3/4	
39	1	360900	FRAME TREE SHEAR W/A	
40	1	360901	JAW TREE SHEAR V3 W/A	
41	1	360902	PUSHBAR TREE SHEAR V3 W/A	
42	1	360903	SLIDER OUTER W/A	Manual Rotate Only
43	1	360904	SLIDER INNER W/A	Manual Rotate Only
44	1	360917	BRKT CYLINDER GAURD PNT	
45	1	360919	BRKT VALVE MOUNT PNT	Hydraulic Rotate Only
46	1	360920	PLATE WASHER 0.78 X 4.0 X 0.5 Z	
47	1	360987	PIN CLEVIS 1 X 2.7 Z	Manual Rotate Only
48	1	360988	PIN CLEVIS 1 X 3.2	Manual Rotate Only
49	1	360990	PIN 2 X 4.563 W/A Z	
50	2	36310	NUT HEX 1/2 REG	
51	1	37212	NUT HEX 3/8 REV LOCK	
52	7	37214	NUT HEX 1/2 REV LOCK	
53	2	65105	PIN COTTER 5/32 X 1-1/2	
54	1	300852	PIN CLEVIS 1 X 2.5	Hydraulic Rotate Only
55	1	203346	CYLINDER 3 X 8 C-C	Hydraulic Rotate Only

# PARTS INFORMATION

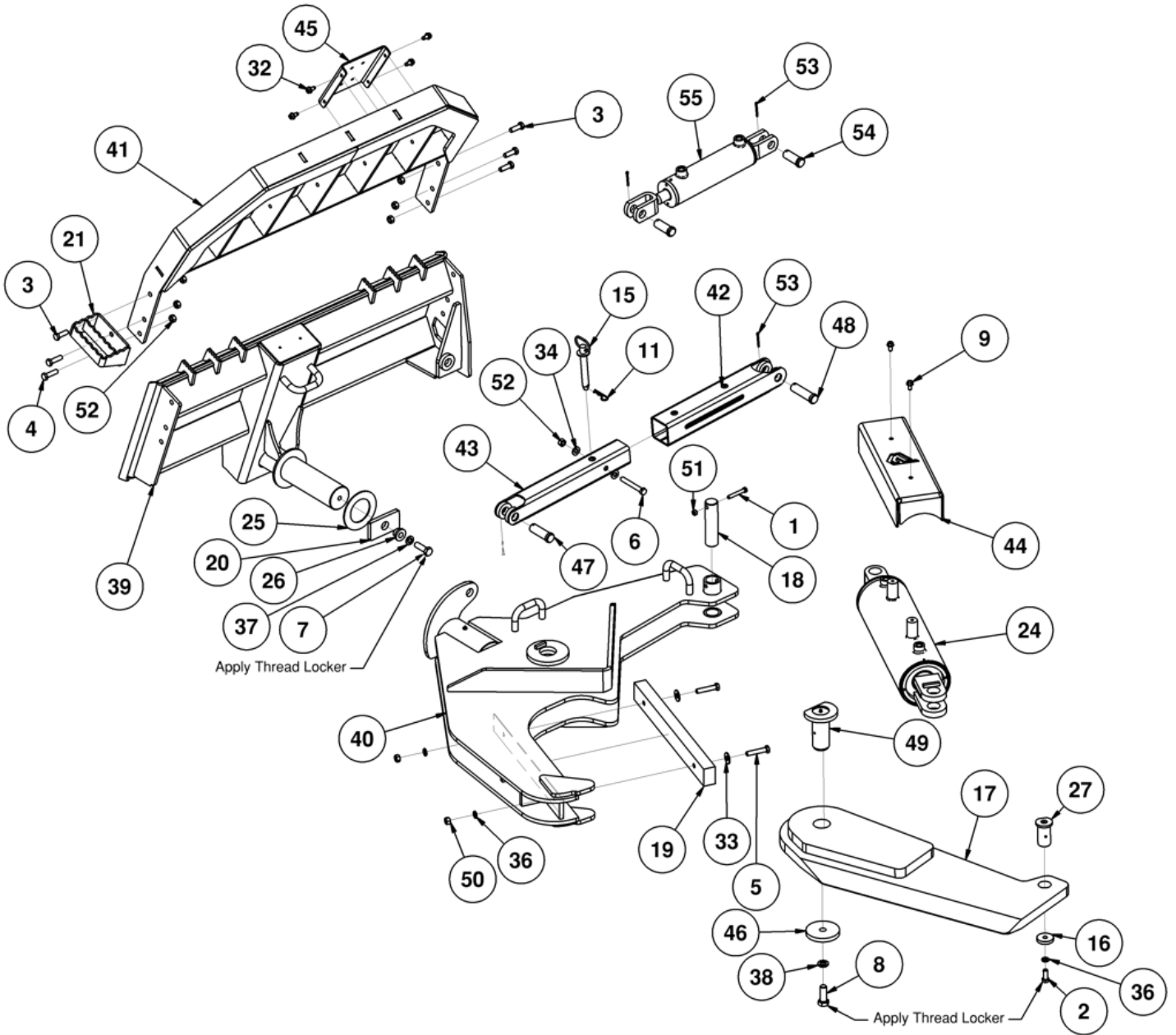

# PARTS INFORMATION

## MANUAL ROTATE

ITEM	QTY	PART NUMBER	DESCRIPTION	NOTES
1	1	316712	HOSE 1/2 X 125 8FJX-8FJX	CYL BASE
2	1	316713	HOSE 1/2 X 141 8FJX-8FJX	CYL ROD
3	1	316725	CYLINDER 5.5 X 14 C-B	
4	2	202037	ADPT ELB 8MB-8MJ-90	
5	2	300708	ADPT STR 12FJ-8MJ	
6	1	300705	COUPLER HYD 1/2-12MJ 90 M FF	
7	1	300704	COUPLER HYD 1/2-12MJ 90 FM FF	

## NOT PICTURED

QTY	PART NUMBER	DESCRIPTION	NOTES
1	321471	SEAL KIT CYL COLUMBUS 316725	SERVICE PARTS

# PARTS INFORMATION

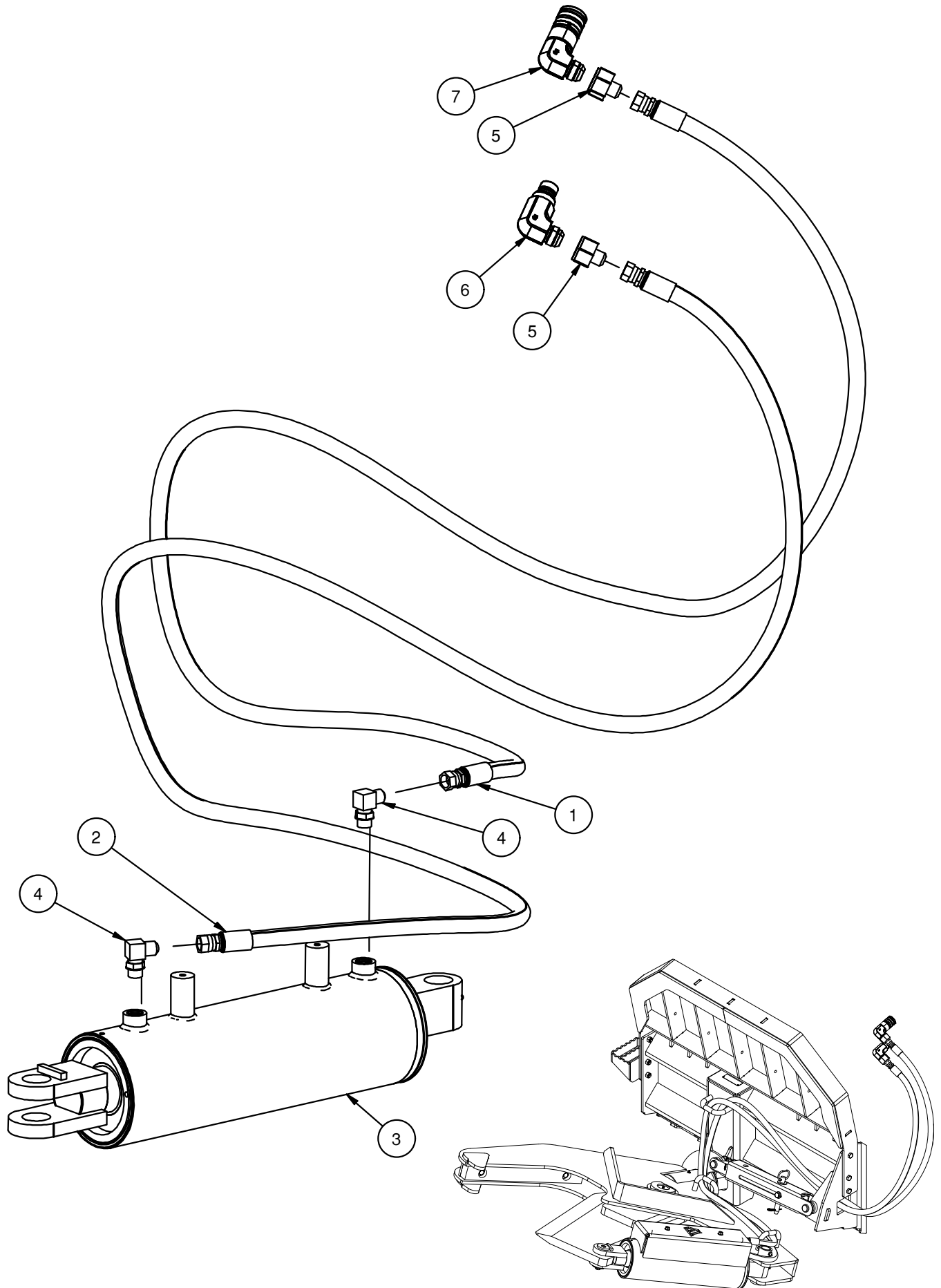

# PARTS INFORMATION

## HYDRAULIC ROTATE

ITEM	QTY	PART NUMBER	DESCRIPTION	NOTES
16	1	316725	CYLINDER 5.5 X 14 C-B	
25	1	203346	CYLINDER 3 X 8 C-C	
28	1	313467	VALVE 6-WAY SELECT ELEC	
37	4	201523	ADPT STR 10MB-8MJ	
38	2	300903	ADPT RESTRICTOR 10MB-6MJ-3/32	
39	1	316707	HOSE 1/2 X 76" 8FJX-8FJX-90	
40	1	316708	HOSE 1/2 X 93" 8FJX-8FJX-90	
41	2	202037	ADPT ELB 8MB-8MJ-90	
42	2	316709	HOSE 3/8 X 34" 6FJX-6FJX-90	
43	2	320089	ADPT ELB 8MB-6MJ-90	
44	2	316710	HOSE 1/2 X 88" 8FJX-8FJX-90	
45	2	300708	ADPT STR 12FJ-8MJ	
46	1	300705	COUPLER HYD 1/2-12MJ 90 M FF	
47	1	300704	COUPLER HYD 1/2-12MJ 90 FM FF	

## NOT PICTURED

QTY	PART NUMBER	DESCRIPTION	NOTES
1	315152	HRN 14-PIN	
1	321461	SEAL KIT CYL COLUMBUS 203346	SERVICE PARTS
1	321471	SEAL KIT CYL COLUMBUS 316725	SERVICE PARTS

# PARTS INFORMATION

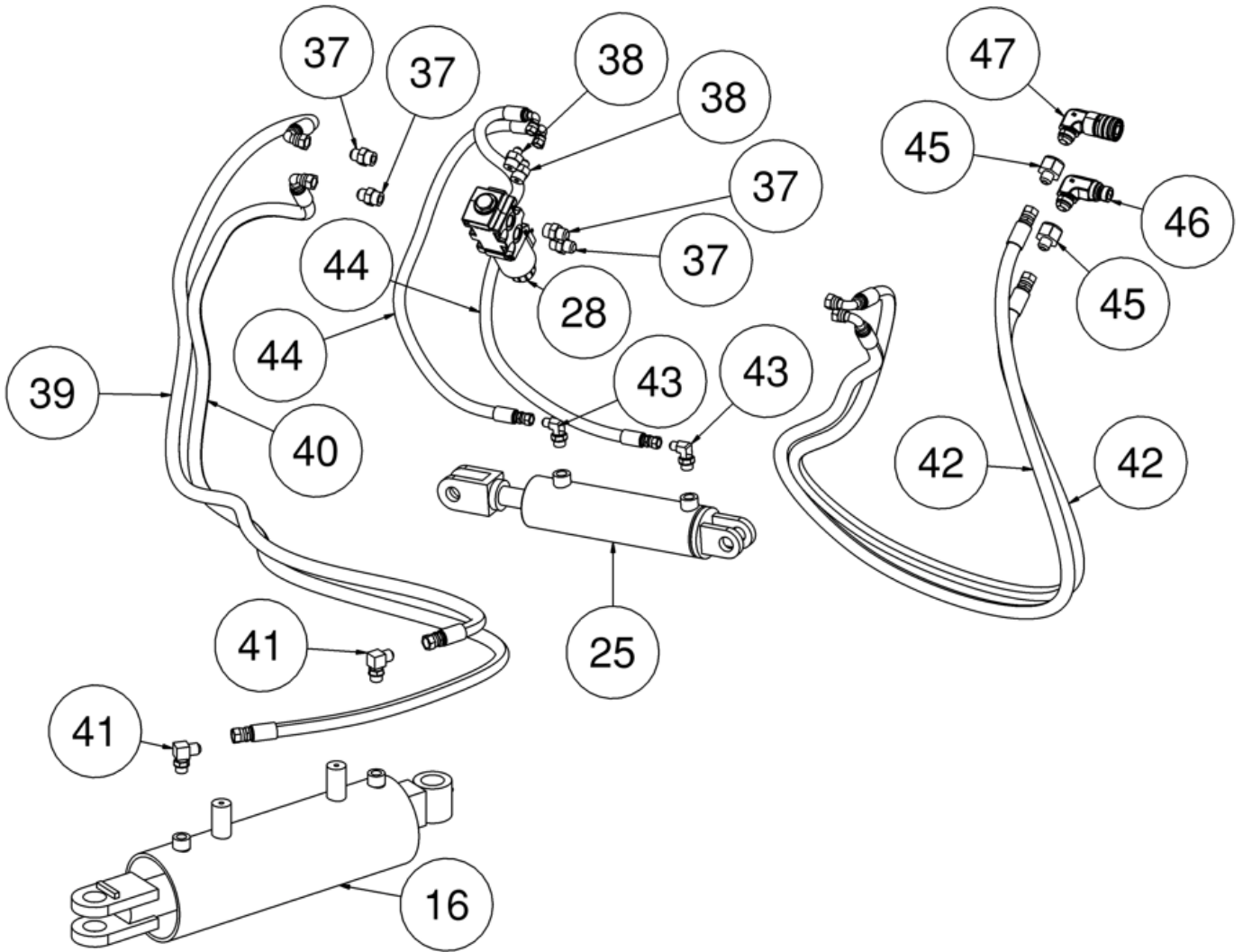

# PARTS INFORMATION

ITEM	QTY	PART NUMBER	DESCRIPTION	NOTE
	1	315128	COMPLETE HARNESS -GENERIC	SHOWN
1	1	315110	PISTOL GRIP	HANDLE ASSEMBLY W/ HARNESS
2	1	315126	LOADER HARNESS	
3	1	202489	RECEPTACLE BRACKET	FOR LOADER HARNESS
4	1	315127	ATTACHMENT HARNESS	

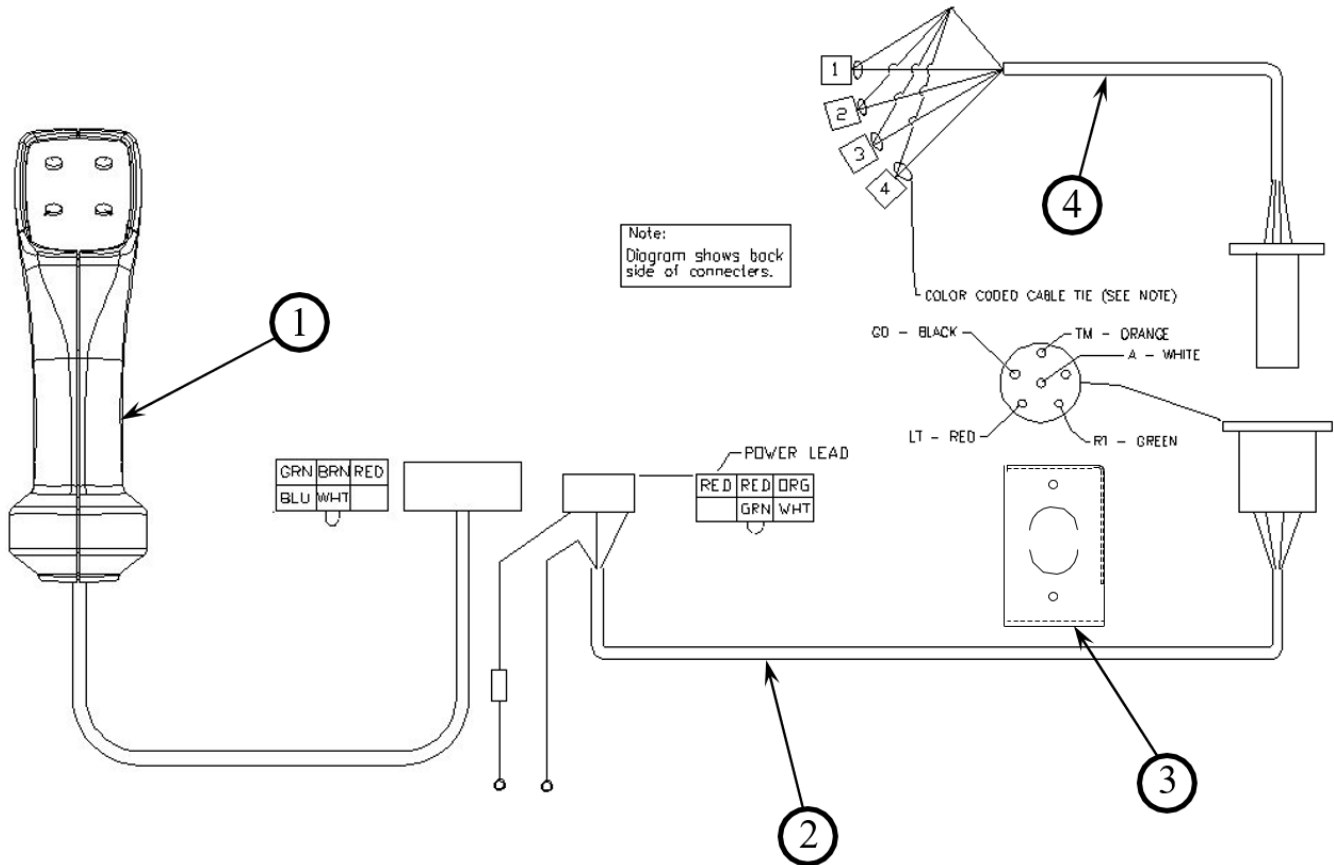

## OPTIONAL HARNESSES (NOT SHOWN)

PART NUMBER	DESCRIPTION	NOTE
315090	HARNESS 14-PIN UNIVERSAL	FOR BOBCAT® LOADERS
315152	HARNESS 14-PIN UNIVERSAL	FOR CASE® & NEW HOLLAND® LOADERS
320084	HARNESS 14-PIN UNIVERSAL	FOR JOHN DEERE® LOADERS PRIOR TO D SERIES
320647	HARNESS 14-PIN UNIVERSAL	FOR JOHN DEER® EH LOADERS
300444	HARNESS 14-PIN UNIVERSAL	FOR KUBOTA® LOADERS
200008	HARNESS 8-PIN	FOR CATERPILLAR® A SERIES LOADERS
315153	HARNESS 8-PIN	FOR ASV® LOADERS
315339	HARNESS 8-PIN	FOR CATERPILLAR® B SERIES HIGH FLOW LOADERS

# GENERAL SPECS

MODEL	POWER AXE MANUAL ROTATE	POWER AXE HYD ROTATE
PART NUMBER	902150	902151
CYLINDER	5.5" X 14	5.5" X 14
MAX. CUTTING DIAMETER	14"	14"
JAW ROTATION ANGLE	90 DEGREES	90 DEGREES
MAX HYDRAULIC PRESSURE	3000 PSI	3000 PSI
SHIPPING WEIGHT (LBS)	1040	1056
OPERATING WEIGHT (LBS)	934	950

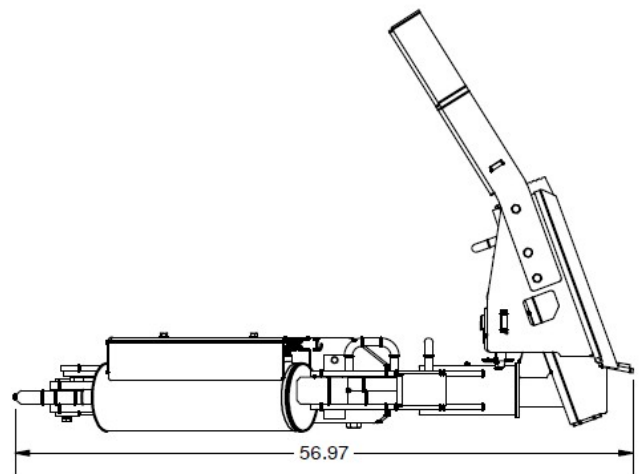
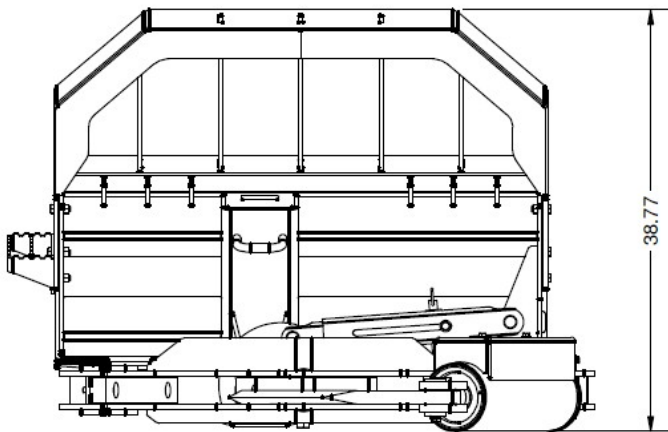
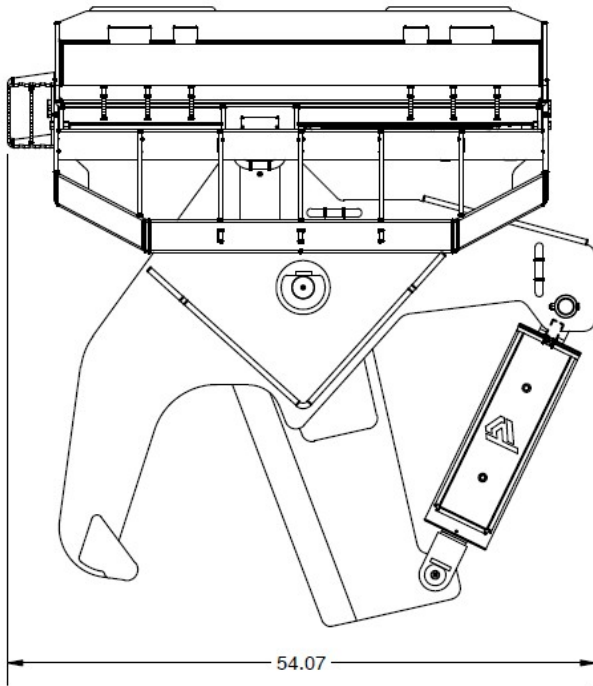

# TORQUE INFORMATION

## Torque-Tension Relationships for SAE J429 Grade Bolts

Nominal Thread Size	SAE J429 Grade 2			SAE J429 Grade 5			SAE J429 Grade 8		
	Clamp Load (lbs)	Tightening Torque		Clamp Load (lbs)	Tightening Torque		Clamp Load (lbs)	Tightening Torque	
		K = .15	K = .20		K = .15	K = .20		K = .15	K = .20
<b>Unified Coarse Thread Series</b>									
1/4-20	1,300	49 in-lbs	65 in-lbs	2,000	75 in-lbs	100 in-lbs	2,850	107 in-lbs	143 in-lbs
5/16-18	2,150	101	134	3,350	157	210	4,700	220	305
3/8-16	3,200	15 ft-lbs	20 ft-lbs	4,950	23 ft-lbs	31 ft-lbs	6,950	32.5 ft-lbs	44 ft-lbs
7/16-14	4,400	24	30	6,800	37	50	9,600	53	70
1/2-13	5,850	36.5	49	9,050	57	75	12,800	80	107
9/16-12	7,500	53	70	11,600	82	109	16,400	115	154
5/8-11	9,300	73	97	14,500	113	151	20,300	159	211
3/4-10	13,800	129	173	21,300	200	266	30,100	282	376
7/8-9	11,425	125	166	29,435	321	430	41,550	454	606
1-8	15,000	187.5	250	38,600	482.5	640	54,540	680	900
<b>Unified Fine Thread Series</b>									
1/4-28	1,500	55 in-lbs	75 in-lbs	2,300	85 in-lbs	115 in-lbs	3,250	120 in-lbs	163 in-lbs
5/16-24	2,400	112	150	3,700	173	230	5,200	245	325
3/8-24	3,600	17 ft-lbs	22.5 ft-lbs	5,600	26 ft-lbs	35 ft-lbs	7,900	37 ft-lbs	50 ft-lbs
7/16-20	4,900	27	36	7,550	42	55	10,700	59	78
1/2-20	6,600	41	55	10,200	64	85	14,400	90	120
9/16-18	8,400	59	79	13,000	92	122	18,300	129	172
5/8-18	10,600	83	110	16,300	128	170	23,000	180	240
3/4-16	15,400	144	193	23,800	223	298	33,600	315	420
7/8-14	12,610	138	184	32,480	355	473	45,855	500	668
1-12	16,410	205	273	42,270	528	704	59,670	745	995

Clamp load estimated as 75% of proof load for specified bolts.

Torque values for 1/4 and 5/16 inch series are in inch-pounds. All other torque values are in foot-pounds.

Torque values calculated from formula  $T = KDF$

where:  $K=0.15$  for "lubricated" conditions

$K=0.20$  for "dry" conditions



## LIMITED WARRANTY

Quick Attach Attachments, LLC warrants each new machine manufactured by us to be free from defects in material and workmanship for a period of twenty-four (24) months from date of delivery to the original purchaser.

Our obligation under this warranty is to replace free of charge, at our factory or Direct Outlet locations, any part proven defective within the stated warranty time limit.

All parts must be returned freight prepaid and adequately packaged to prevent damage in transit.

This warranty does not cover:

1. New products which have been operated in excess of rated capacities or negligence
2. Misuse, abuse, accidents or damage due to improperly routed hoses
3. Machines which have been altered, modified or repaired in any manner not authorized by our company
4. Previously owned equipment
5. Any ground engaging tools in which natural wear is involved, i.e. tooth tips, cutting teeth, etc
6. Normal maintenance
7. Fork tines
8. Hydraulic motors that have been disassembled in any manner

In no event will the Sales Representative, Direct Outlet, Quick Attach Attachments, LLC, or any other company affiliated with it or them be liable for incidental or consequential damages or injuries, including but not limited to the loss of profit, rental or substitute equipment or other commercial loss. Purchaser's sole and exclusive remedy being as provided here in above.

Quick Attach Attachments, LLC must receive immediate notification of defect and no allowance will be made for repairs without our consent or approval.

This warranty is in lieu of all other warranties, express or implied by law or otherwise, and there is no warranty of merchantability or fitness purpose.

No agent, employee, or representative of Quick Attach Attachments, LLC has any authority to bind Quick Attach Attachments, LLC to any warranty except as specifically set forth herein. Any of these limitations excluded by local law shall be deemed deleted from this warranty; all other terms apply.

This warranty may not be enlarged or modified in any manner except in writing signed by an executive officer of Quick Attach Attachments, LLC to improve its products whenever it is possible and practical to do so. Quick Attach Attachments, LLC reserves the right to make changes and or add improvements at any time without incurring any obligation to make such changes or add such improvements to products previously sold.

Quick Attach Attachments, LLC  
P.O. Box 128 Alexandria, MN 56308  
Phone (320) 759-1551  
Fax (320) 759-1590

