

Operation & Maintenance Manual

EZ MowTM **Brush Mower** **Models 66 / 72 / 78**

For

Skid Steer Loaders



Read this Manual Before Use

<u>SAFETY</u>	3-4
<u>SERIAL NUMBER/DECAL LOCATION</u>	5-6
<u>MOUNTING INSTRUCTIONS</u>	7-8
<u>OPERATING INSTRUCTIONS</u>	9
<u>ROUTINE MAINTENANCE</u>	10-13
<u>PARTS INFORMATION</u>	14-16
<u>GENERAL SPECIFICATIONS</u>	17
<u>BOLT TORQUE INFORMATION</u>	18
<u>WARRANTY</u>	19

REFERENCE INFORMATION

Write the serial number for your attachment in the spaces below. Always refer to this serial number when calling for service or parts.

Serial Number....._____

YOUR ATTACHMENTS DEALER

ADDRESS:

PHONE:

CONTACT:

NOTE: *Quick Attach Attachments LLC reserves the right to make improvements in design or changes in specifications at any time without notice and without incurring any obligations to install them on units previously sold.*

SAFETY

DO NOT use or perform maintenance on this machine until this manual has been read and understood. In addition, read the Operation and Maintenance Manual(s) pertaining to the attachment and the attachment carrier (“Loader”).

The user is responsible for inspecting the machine daily, and for having parts repaired or replaced when continued use of the machine would cause damage, excessive wear to other parts or make the machine unsafe for continued operation.

If an operating procedure, tool device, maintenance or work method not specifically recommended is used; you must satisfy yourself that it is safe for you and others. You must also ensure that the attachment will not be damaged or made unsafe by the procedures you choose.

Quick Attach Attachments LLC cannot anticipate every possible circumstance that might involve potential hazard. The safety messages found in this manual and on the machine are therefore not all inclusive

The signal words **CAUTION**, **WARNING**, or **DANGER** are used to indicate hazards.

⚠ CAUTION Indicates a potentially hazardous situation which, if not avoided, may result in minor or moderate injury.

⚠ WARNING Indicates a potentially hazardous situation which, if not avoided, could result in death or serious injury.

⚠ DANGER Indicates a potentially hazardous situation which, if not avoided, will result in death or serious injury.

The word **IMPORTANT** is used in the text when immediate damage will occur due to improper technique or operation.

The word **NOTE** is used to convey information that is out of context with the manual text; special information such as specifications, techniques, reference information, and other information of a supplementary nature.

Improper operation can cause serious injury or death.

Pre-operation

- This attachment is designed for mowing grass and brush only. **NEVER** use this machine for any other purpose.
- Read the operator's manual for the "Skid Steer Loader." **NEVER** allow untrained people to operate.
- Operating instructions must be given to everyone before operating this attachment and at least once a year thereafter in accordance with OSHA regulations.
- **NEVER** exceed the maximum recommended input power or speed specifications for the attachment. Over-powering or over-speeding the attachment may cause personal injury and/or machine damage.
- Keep all shields, guards, and covers in place.
- Do not modify equipment or add attachments that are not approved by Quick Attach Attachments LLC.
- Use adequate safety warning lights and devices as required by local regulations. Obey all local laws and regulations regarding machine operation on public property.

Operation

- To protect the operator from debris and cab intrusion, loader must have polycarbonate or similar strength door and door must be closed in order to operate the attachment.
- Hydraulic connections may be hot after use. Use gloves if connecting or disconnecting after use.
- Check and be sure all operating controls are in neutral before starting the engine.
- Keep people away from loader, attachment and discharge when in use. This attachment sends objects flying and has rotating parts. **NEVER** direct discharge toward people – rocks and debris can be thrown hundreds of feet.

Operation (continued)

- **NEVER** operate near embankments or terrain that is so steep that rollover could occur.
- Always stay in the operator position when using the attachment.
- Before leaving the operators position, disengage hydraulic drive, lower the attachment to rest flat on the ground, stop engine, set park brake, and wait for all motion to stop.
- **NEVER** place hands in the discharge area or clear debris while engine is running.

Avoid High Pressure Fluids Hazard



- Escaping fluid under pressure can penetrate the skin causing serious injury.
- Avoid the hazard by relieving the pressure before disconnecting hydraulic lines.
- Use a piece of paper or cardboard, NOT BODY PARTS, to check for suspected leaks. Wear protective gloves and safety glasses or goggles when servicing or performing maintenance on hydraulic systems.
- If an accident occurs, see a doctor immediately. Any fluid injected into the skin must be surgically removed within a few hours or gangrene may result.

Maintenance

- **NEVER** make adjustments, lubricate, clean, or perform any service on the machine while it is in operation.
- Make sure the attachment is serviced on a daily basis. Improper maintenance can cause serious injury or death in addition to damage to the attachment and/or your equipment.

SERIAL NUMBER AND SAFETY DECAL LOCATIONS

Serial Number Location:

It is important to refer to the serial number of your attachment when making repairs or ordering parts. Early or later models (identification made by serial number) may use different parts, or it may be necessary to use different procedures in doing a specific operation. Serial number plate is located on the right side of deck.

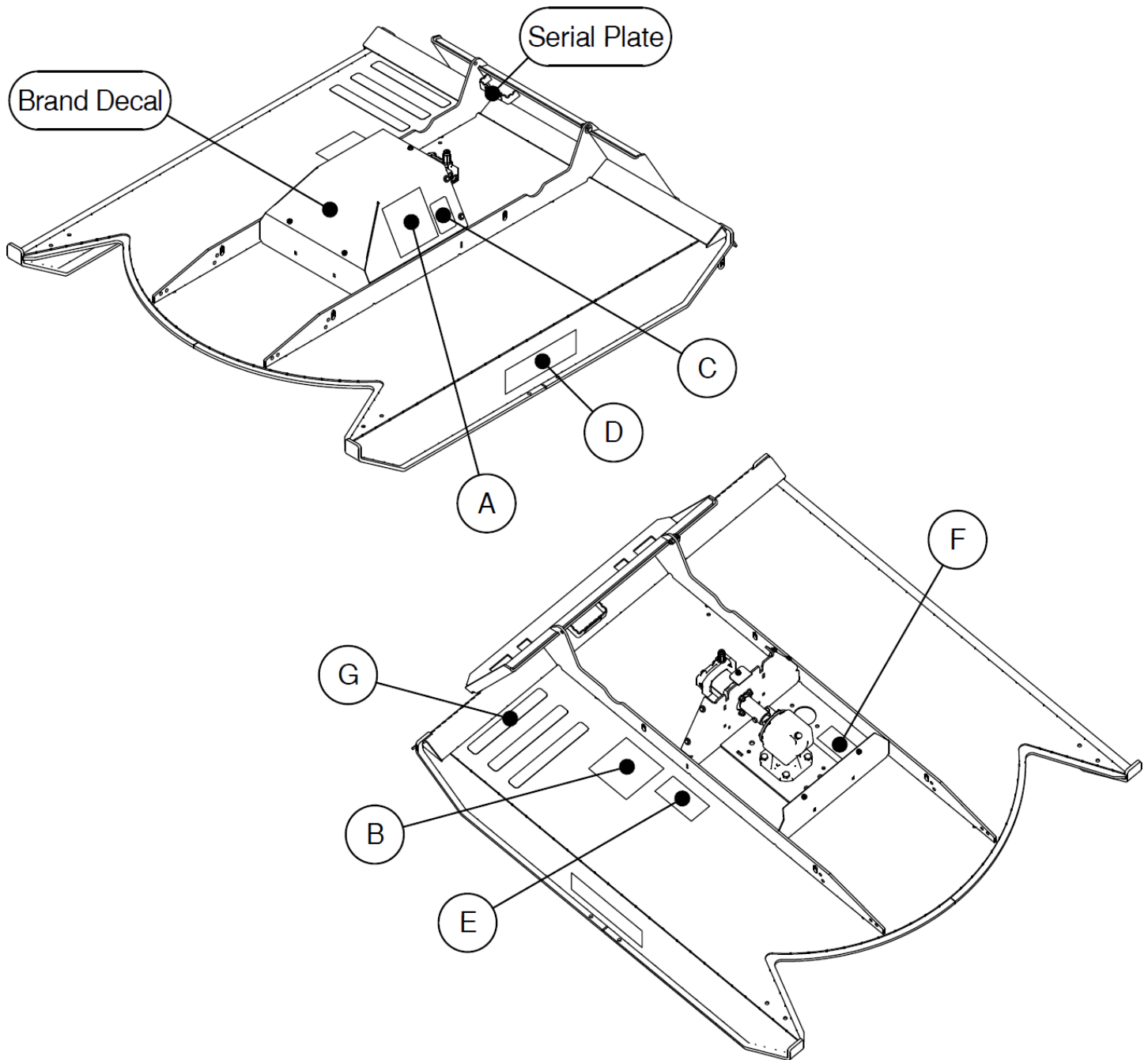

SERIAL NUMBER AND SAFETY DECAL LOCATIONS

Safety Decals Locations:

The locations of the safety decals are shown. If these decals are missing, damaged, or painted over they must be replaced. Call Quick Attach Attachments LLC (320-759-1551) for replacement decals.

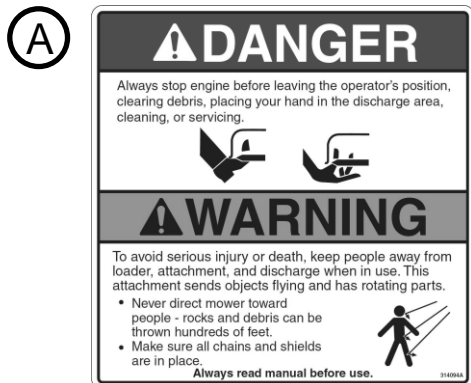

Part number: 314094

Location: Both sides of gearbox cover

Quantity: 2

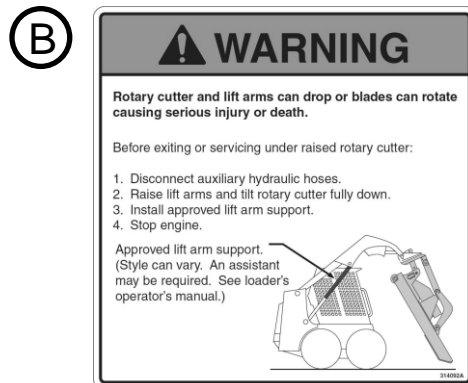

Part Number: 314092

Location: Top of deck, right side

Quantity: 1



Part Number: 200001

Location: Left side of gearbox cover

Quantity: 1



Part Number: 400493

Location: Left and right sides of deck

Quantity: 2



Part Number: 314158

Location: Top of deck, right side

Quantity: 1

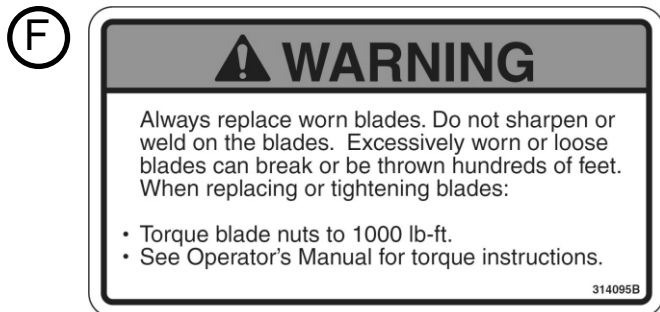

Part Number: 314095

Location: Next to blade bolt access cover

Quantity: 1

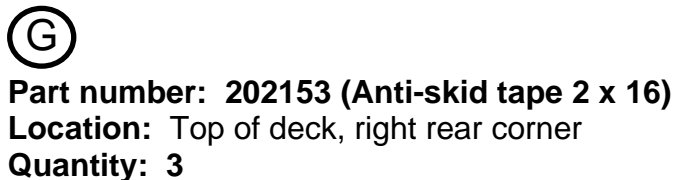

Large Brand Decal

Location: Centered on front of gearbox cover

Quantity: 1

MOUNTING INSTRUCTIONS

After the initial set-up assembly is complete, use the following procedure to mount the attachment to the loader for user operation.



1. Use the step, treads, and grab handles to get on and off the loader and attachment.
2. Sitting in the operator's seat, lower seat bar and fasten the seat belt.
3. Drive the loader to the rear of the attachment. Put the loader quick attach coupler into the attachment mounting bracket.
4. Tilt the loader coupler backward a small amount until it is fully engaged in the attachment mounting bracket.
5. Stop the engine and engage the park brake.
6. Secure the coupler locking mechanism that attaches the attachment to the loader.



⚠ WARNING Coupler wedges or pins must extend through the holes in the attachment mounting plate. Levers must be fully down and locked. Failure to secure wedges or pins can allow attachment to come off and cause injury or death.

7. Route the lift limit chain over the boom cross-member and down through a hole in the front frame. Then latch the end of the chain back to itself allowing for some slack. Make sure the chain will not contact the rotating blades when mowing in reverse.



⚠ WARNING Lift limit chain must be installed to limit the total lift height of the attachment to less than 12 inches (300 mm). Failure to install the lift limit chain can increase the risk of dangerous flying debris being thrown at the cab causing serious injury or death.

MOUNTING INSTRUCTIONS

8. Connect the hydraulic quick couplers from the attachment to the loader.

Be sure to thread the hoses through the hose holder on the loader arm, if so equipped. If no hose holders are installed, contact the dealer that services your loader for assistance. Bungee straps can be used as an alternate method of securing the hoses.

IMPORTANT: Make sure the quick couplers are fully engaged. If the quick couplers do not fully engage, check to see that the couplers are the same size and brand. Do not force the quick couplers together.

IMPORTANT: Wipe the ends of the hydraulic quick couplers (both lead and loader) with a rag to remove any possible contamination. Contamination can cause hydraulic components to fail and is not covered under warranty.

NOTE: Attachment is shipped with 12FJX (1-1/16" Female JIC Swivel) fittings on the ends of the lead hoses.

9. Make sure the hoses are properly routed to fit your specific loader. If the hoses are not routed correctly, hoses may get pinched or rub on tires. Be sure to check the hose routing through the full range of intended motion of the attachment before operating it.

More than one routing may be acceptable depending on the loader. Pick the routing that best suits your loader.

IMPORTANT: Proper hose routing is the responsibility of the owner and/or operator. Pinched or stretched hoses are not covered under warranty.

Mounting is now complete and you are ready to use the attachment. Use reverse order of above instructions to dismount the attachment from the loader.

NOTE: It is normal for the mower to make a loud noise while spinning down after being shut off. This is from the relief valve braking the spinning blades.

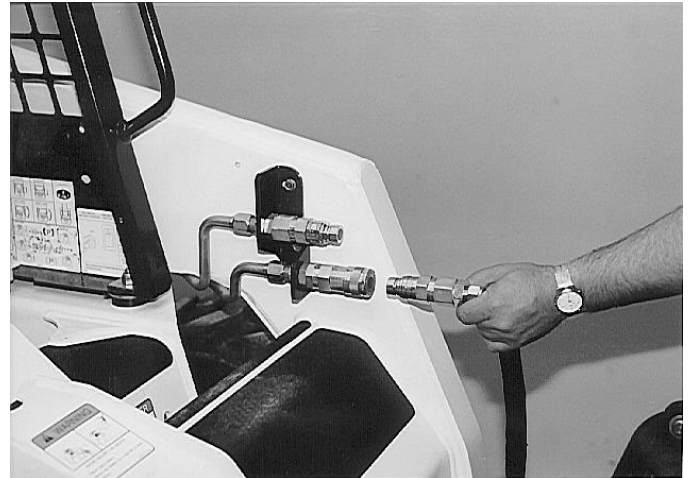

OPERATING INSTRUCTIONS

⚠ WARNING Never operate without lift limit chain installed. Never modify the lift limit chain. To reduce the risk of injury or death check that it is operating properly when you first use a machine, after service, or anytime someone may have disconnected the lift limit chain.

The type of brush being cut and the ground conditions will determine the best ground speed and cutting procedure. The brush mower is designed to cut short or tall grass and brush.

IMPORTANT: Before operating the attachment, perform the service schedule for routine maintenance.

1. Inspect the cutting area for obstructions such as stumps, wire, rocks, electrical lines, debris, drop offs, holes, etc. Remove obstructions from the cutting area that might be picked up and thrown.
2. With the operator in the seat of the loader, the seat belt fastened and the seat bar lowered (if so equipped), start the engine.

⚠ WARNING To improve stability, always carry the attachment low to the ground while driving.

3. Activate the auxiliary hydraulic system to start the blade rotation. Make sure auxiliary hydraulic circuit is operating in the correct direction.

IMPORTANT: Engine must be at idle speed when engaging auxiliary hydraulic system.

IMPORTANT: Operating at higher flow rates than specified can cause serious damage to the mower and will void the warranty. See “General Specifications” for recommended flow rates.

IMPORTANT: Do not operate the brush mower if excessive vibration is present. Serious damage can occur. Check blades and gearbox.

4. With the loader boom lowered all the way and the auxiliary hydraulics engaged, slowly rotate the loader coupler forward until the skid plates are parallel to the ground.

NOTE: It may be helpful in certain instances to keep the front of the mower raised slightly.



IMPORTANT: Do not operate the brush mower if excessive vibration is present. Serious damage can occur. Check blades and gearbox.

5. With the loader boom lowered all the way and the auxiliary hydraulics engaged, slowly rotate the loader coupler forward until the skid plates are parallel to the ground.

NOTE: It may be helpful in certain instances to keep the front of the mower raised slightly.

6. If desired, the loader lift arms can be put in the float position. (See loader's operator's manual.)

6. Drive the loader forward into the work area.

NOTE: Raising the front of the brush mower a few inches may help while driving forward into thick brush and when turning.

ROUTINE MAINTENANCE

⚠ WARNING Lower the attachment to rest flat on the ground, shut down the engine, relieve the hydraulic pressure to the attachment, wait for all motion to stop, and set park brake before leaving the operator's seat to perform service of any kind.

It is the operator's responsibility to make daily inspections of the attachment and loader for damage, loose bolts, fluid leaks, or anything else that could cause a potential service or safety problem. Preventive maintenance is the easiest and least expensive type of maintenance.

IMPORTANT: Bolts and set screws can loosen after initial usage. After first hour of operation check all bolts and set screws. This must also be done daily before operation. If nuts or bolts are missing or damaged, replace immediately.

DAILY INSPECTION

Check the following items daily before operation of the attachment:

1. Check lift chain and shackle for damage or defects.
2. Check blades for cracks or damage. Replace if necessary.
3. Check blade mounting hardware for proper torque of 1000ft. lbs. (1355Nm). Tap bolt head with hammer and retorque.
4. Check all hardware. Retighten if necessary.
5. Check chains, deck, and shields. Repair if damaged or replace if necessary.
6. Check for damaged or missing decals. Replace if missing.
7. Check for damaged or leaking hydraulic hoses or fittings. Replace if necessary.
8. Clean debris, leaves, grass, and flammable material from deck area and under covers.
9. Check lubrication level in gearbox (use EP80W-90 or EP85W-140 gear lube). Capacity is approximately 29oz.
10. Check that the antiskid treads are in good condition.

Gearbox Fluid Check and Fill

Position the attachment flat on the ground.

Remove the level check plug [B] to check the fluid level in the gearbox. Fluid must be level with the check plug hole.

To add EP80W-90 or EP85W-140 gear lube, remove the fill plug [A] and add lube until it is level with the check plug hole.

IMPORTANT: Fluids such as engine oil, gear lube, and hydraulic fluid must be disposed of in an environmentally safe manner. Some regulations require that certain spills and leaks be cleaned in a specific manner. Check local, state, and federal regulations for the correct disposal procedure.

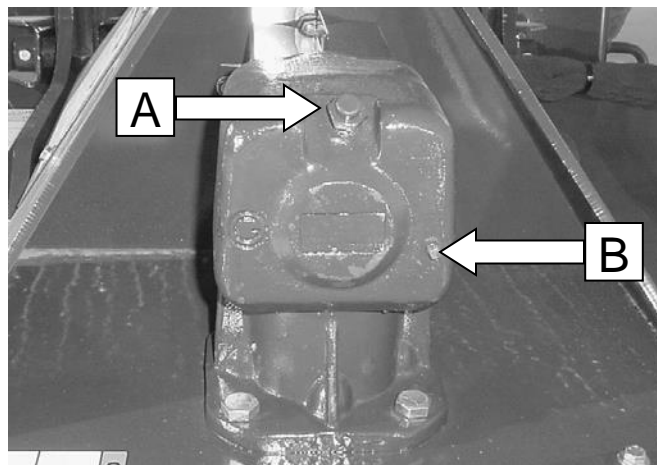

ROUTINE MAINTENANCE



Cleaning the Brush Mower

⚠ WARNING To avoid injury or death, before exiting under or servicing under the attachment, be sure to disconnect the auxiliary hydraulic hoses. Raise the lift arms and tilt the attachment down fully. Install an approved lift arm support and stop the engine.

1. Position the attachment by raising the lift arms and tilting the attachment down as shown. Use an arm lock when working with arms raised. This may require the help of an assistant. Refer to loader's operator's manual for arm locking instructions. Keep the front edge of the attachment within one foot of the ground for debris clean out or blade service.

2. Exit the loader.

⚠ WARNING Always wear eye protection that meets ANSI z87.1 standard when cleaning.

3. Use water or a small brush to clean debris from the areas under the cover and around the gearbox.

⚠ WARNING Use care when removing any debris that is wrapped around the blades, stump jumper, or gearbox shaft. Blades can rotate suddenly.

Reversing Blade Rotation

The brush mower is equipped with double-sided blades. When the original side is worn down, the direction of blade rotation can be reversed to use the other side of the blades. To reverse the blade direction, run the loader's continuous flow hydraulics in the reverse flow direction, or swap the positions of the lead hoses in the motor and continue to run the hydraulics in the forward flow direction.

When both edges of the blades are excessively worn, replace both blades.

⚠ WARNING Always replace worn blades. Do not sharpen or weld on the blades. Excessively worn blades can break and be thrown hundreds of feet.

IMPORTANT: Always replace both blades with two that are equal in weight to prevent vibration. Always use genuine Quick Attach™ replacement blades.

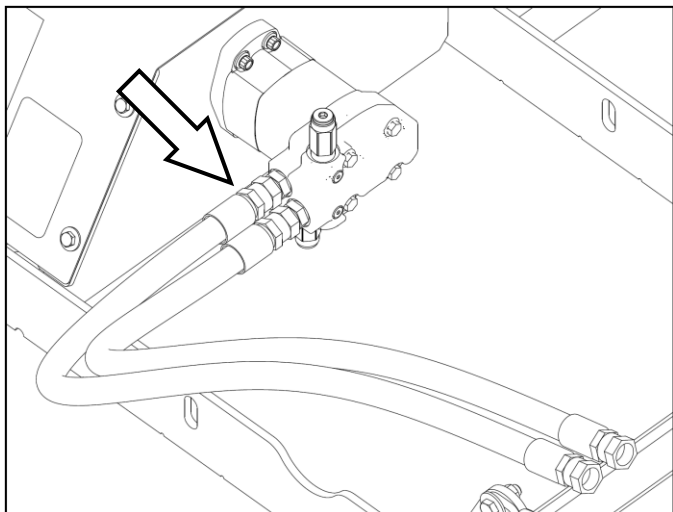

ROUTINE MAINTENANCE

Blade Removal and Installation

NOTE: Refer to “Daily Inspection” on page 12 of this manual for daily maintenance check. Check that the blades can swing freely. Also check blades, mounting hardware, and stump jumper for wear, cracking, or breakage, which can cause excessive vibrations. Replace if damaged.

Only service the blades when attachment is attached to the loader.

⚠ WARNING To avoid injury or death, before exiting under or servicing under the attachment, be sure to disconnect the auxiliary hydraulic hoses. Raise the lift arms and tilt the attachment down fully. Install an approved lift arm support and stop the engine.

⚠ WARNING Bent, deformed, cracked, or damaged blades should be removed from the unit and discarded immediately. Never attempt to repair or reuse a damaged blade.

⚠ WARNING Always replace worn blades. Do not sharpen or weld on the blades. Excessively worn blades can break and be thrown hundreds of feet.

⚠ WARNING Wear safety glasses and gloves when removing and installing blades.

Removal:

1. Remove the gearbox cover to expose the blade access hole.
2. Rotate the stump jumper [A] until the bolt [B] is accessible from the front of the mower, and use a hammer and punch to remove the roll pin.
3. Rotate the stump jumper [A] until the bolt [B] is aligned with the access hole.
4. Remove the slotted nut from the blade bolt.

NOTE: Blade bolt and blade may fall from the stump jumper when removing the blade nut. Always support the blade bolt and blade while removing the slotted nut.

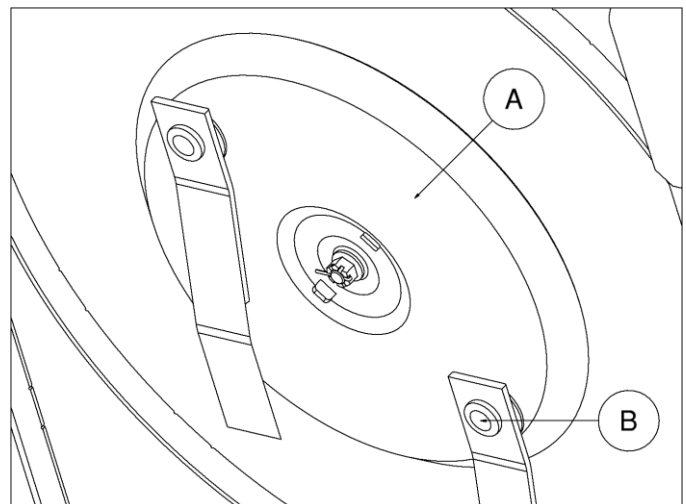
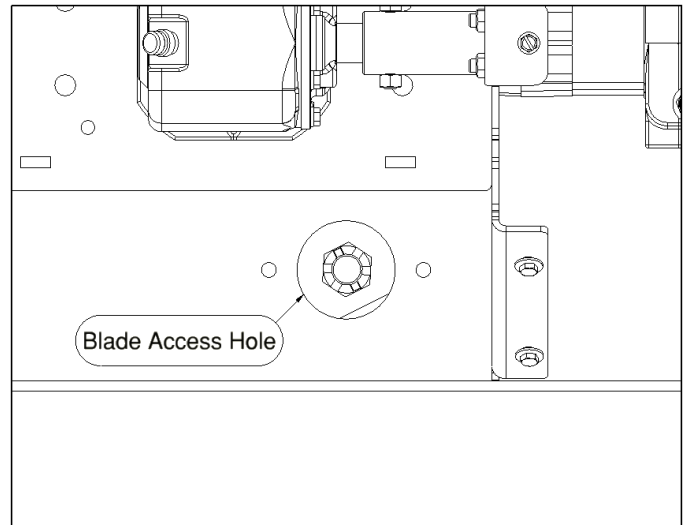

ROUTINE MAINTENANCE

Installation:

1. Always use a **new** slotted nut, bolt, and roll pin during assembly.

NOTE: The blade bolt fits only one way into the stump jumper. Install the washer between the blade and the stump jumper.

NOTE: To assist with slot alignment, mark the cross-hole position on the end of the bolt before installation.

2. Tighten the slotted nut to 1000 ft. lbs. (1355 Nm) torque. Continue to tighten the nut until the slots align with the bolt cross-hole.
3. Install the roll pin through the bolt and nut.
4. Repeat the procedure for the other blade.

Blade Carrier Removal

1. Support the mower so that it is in a safe and secure position. We recommend tipping the mower up on its nose with a hoist.
2. Secure the stump jumper with a chain hoist.
3. Remove the cotter pin and castle nut from the stump jumper shaft.
4. Use a puller to free the stump jumper from the shaft, taking care not to let it fall.

IMPORTANT: When reinstalling the stump jumper, torque the hub nut to 600 ft.-lbs.

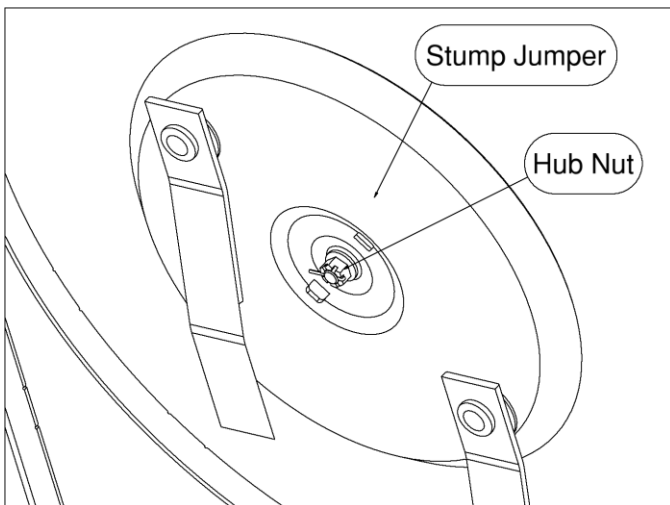
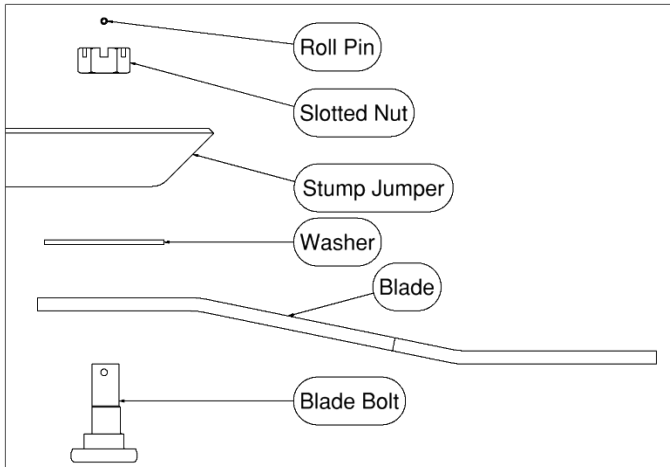

BRUSH MOWER UTILITY PARTS INFORMATION

ITEM	QTY	PART NO.	DESCRIPTION	STOCK NO.
1	1	350535	DECK 66 UTILITY MOWER V4 W/A	
	1	350536	DECK 72 UTILITY MOWER V4 W/A	
	1	350537	DECK 78 UTILITY MOWER V4 W/A	
2	1	314120	GEARBOX RC51 PAINTED	
3	4	15311	BOLT HEX	BOLT 5/8 X 2 NC GR 8 YZ
4	1	341337	MOTOR 6.2 2K MAG 2RELIEF	66" LOW FLOW
	1	341338	MOTOR 8.0 2K MAG 2RELIEF	66"
	1	341339	MOTOR 9.6 2K MAG 2RELIEF	72"
	1	341340	MOTOR 11.9 2K MAG 2RELIEF	78"
5	4	22888	BOLT FLG 12 PT	1/2 X 1-3/4 NC Z
6	4	0167011	NUT FLG TOP-LOCK	1/2 NC GR G (GR8)
7	1	350519	COUPLER MOWER 1.25-14T X 1.38	
8	1	13214	BOLT HEX	1/2 X 2-3/4 NC GR 5
9	2	37214	NUT REV LOCK	1/2 NC GR A Z
10	1	350269	COVER GEARBOX W/A	
11	3	32467	BOLT FLG THRD RLNG	3/8 X 3/4 NC
12	4	13107	BOLT HEX	3/8 X 1-1/4 NC GR 5
13	8	33008	WASHER FLAT	3/8
14	1	400462	CHAIN LINK 5/16 X 5 FT	
15	1	400463	SHACKLE SCREW PIN 3/8	
16	1	13209	BOLT HEX	1/2 X 1-1/2 NC GR 5
17	1	33012	WASHER FLAT	1/2
18	2	202113	ADPT STR 10MB-12MJ	
19	2	330873	HOSE 3/4 X 82" 12FJX-12FJX	
98	2	300698	VALVE RELIEF HIDDEN 3000	FOR PARTS ONLY

BRUSH MOWER UTILITY PARTS INFORMATION

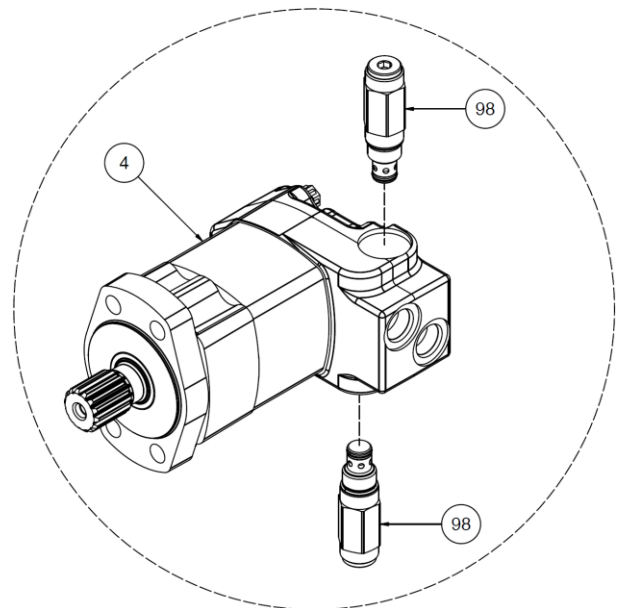
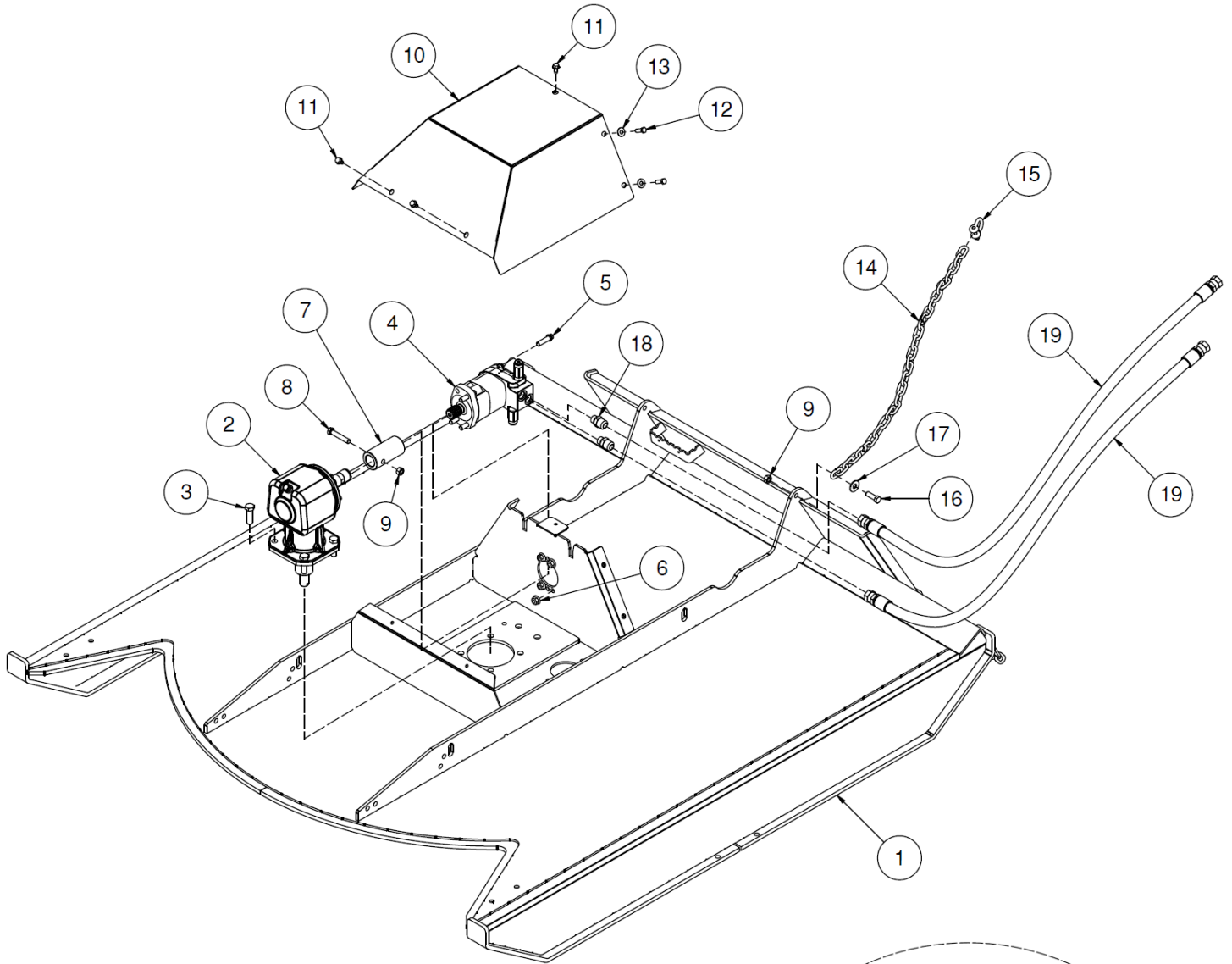

BRUSH MOWER UTILITY PARTS INFORMATION

ITEM	QTY	PART NO.	DESCRIPTION	STOCK NO.
20	1	350525	STUMP JUMPER 15T 25.25 HEX W/A	72"
	1	350526	STUMP JUMPER 15T 32.25 HEX W/A	66" & 78"
21	1	120050	CASTLE NUT 1-14UNS-2B FLG	COMES WITH GEARBOX
22	1	65127	PIN COTTER 3/16 X 2	COMES WITH GEARBOX
23	2	350504	WASHER 1.137 HEX ID X 4.50 OD	
	2	314063	BLADE MOWER 60	66"
24	2	314098	BLADE MOWER 72	72" & 78"
25	2	421489	BOLT BLADE HEX 1-1/8 NF X 3.20	
26	2	331371	NUT HEX 1-1/8-12 SLOTTED GR8	
27	2	331373	PIN ROLL 1/4 X 1.625 Z	
28	4	0167012	NUT FLG TOP-LOCK	
99		350530	BLADE KIT BM 60/66 HEX	FOR PARTS (66")
		350531	BLADE KIT BM 72/78 HEX	FOR PARTS (72" & 78")

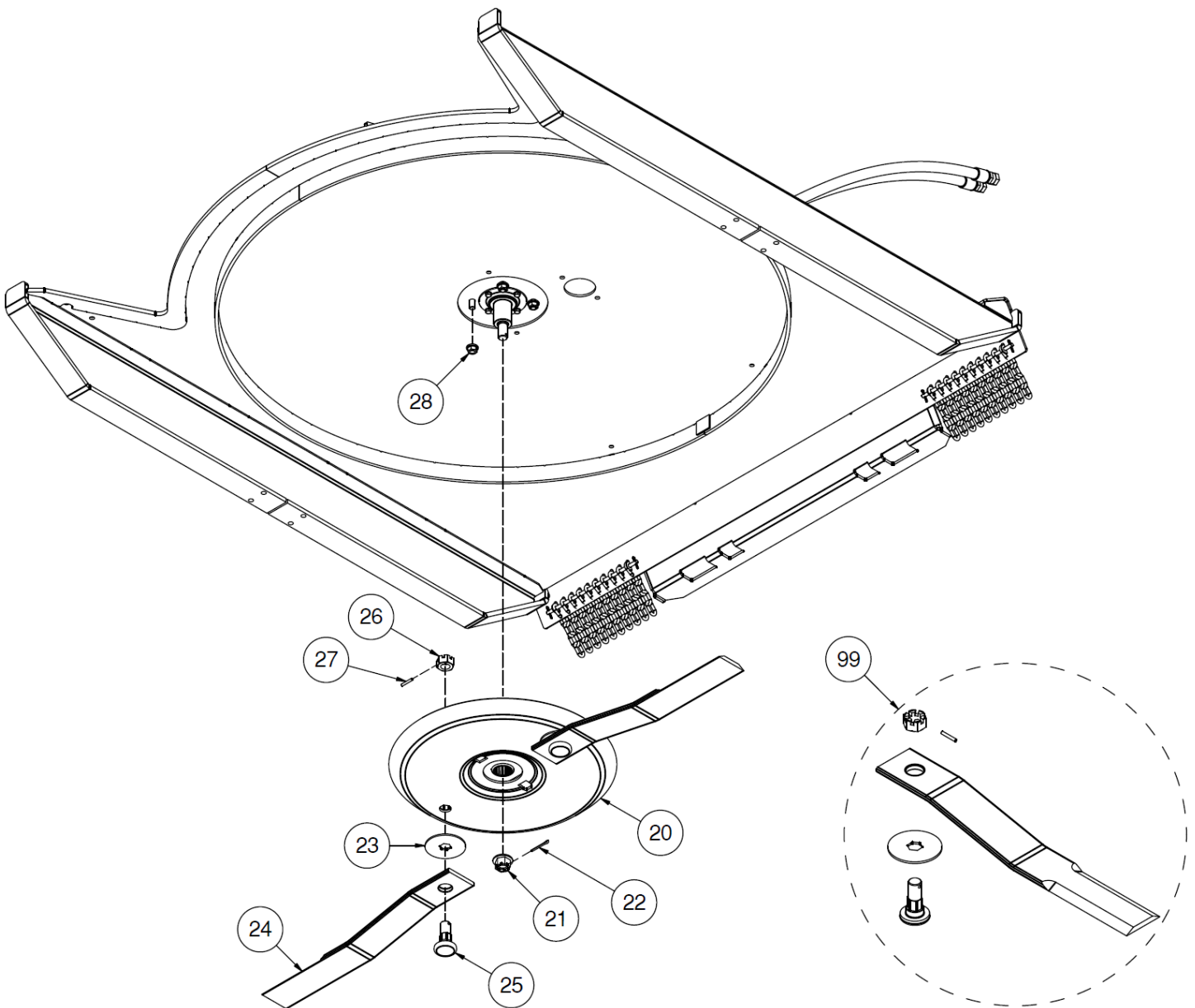

GENERAL SPECIFICATIONS

Model	66" Low Flow	66"	72"	78"
Hydraulic Flow Requirements	13 to 17 GPM	18 to 27 GPM	17 to 32 GPM	17 to 32 GPM
Operating Weight	1,025 lbs.	1,025 lbs.	1,080 lbs.	1,210 lbs.
Cutting Diameter	66"	66"	72"	78"
Cutter Capacity	Brush material up to 3"			

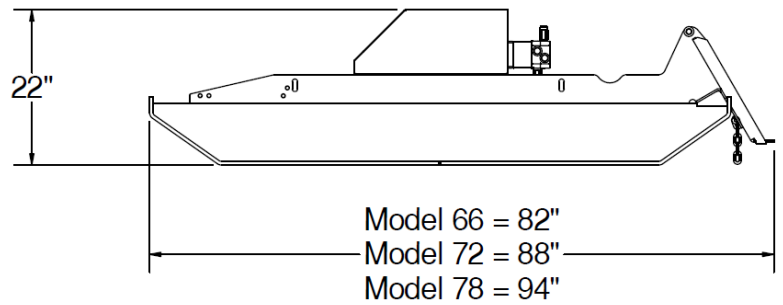
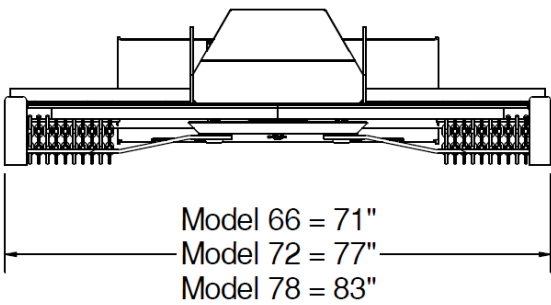

All dimensions are in INCHES.

BOLT TORQUE INFORMATION

Torque-Tension Relationships for SAE J429 Grade Bolts

Nominal Thread Size	SAE J429 Grade 2			SAE J429 Grade 5			SAE J429 Grade 8		
	Clamp Load (lbs)	Tightening Torque		Clamp Load (lbs)	Tightening Torque		Clamp Load (lbs)	Tightening Torque	
		K = .15	K = .20		K = .15	K = .20		K = .15	K = .20
Unified Coarse Thread Series									
1/4-20	1,300	49 in-lbs	65 in-lbs	2,000	75 in-lbs	100 in-lbs	2,850	107 in-lbs	143 in-lbs
5/16-18	2,150	101	134	3,350	157	210	4700	220	305
3/8-16	3,200	15 ft-lbs	20 ft-lbs	4,950	23 ft-lbs	31 ft-lbs	6,950	32.5 ft-lbs	44 ft-lbs
7/16-14	4,400	24	30	6,800	37	50	9,600	53	70
1/2-13	5,850	36.5	49	9,050	57	75	12,800	80	107
9/16-12	7,500	53	70	11,600	82	109	16,400	115	154
5/8-11	9,300	73	97	14,500	113	151	20,300	159	211
3/4-10	13,800	129	173	21,300	200	266	30,100	282	376
7/8-9	11,425	125	166	29,435	321	430	41,550	454	606
1-8	15,000	187.5	250	38,600	482.5	640	54,540	680	900
Unified Fine Thread Series									
1/4-28	1,500	55 in-lbs	75 in-lbs	2,300	85 in-lbs	115 in-lbs	3,250	120 in-lbs	163 in-lbs
5/16-24	2,400	112	150	3,700	173	230	5,200	245	325
3/8-24	3,600	17 ft-lbs	22.5 ft-lbs	5,600	26 ft-lbs	35 ft-lbs	7,900	37 ft-lbs	50 ft-lbs
7/16-20	4,900	27	36	7,550	42	55	10,700	59	78
1/2-20	6,600	41	55	10,200	64	85	14,400	90	120
9/16-18	8,400	59	79	13,000	92	122	18,300	129	172
5/8-18	10,600	83	110	16,300	128	170	23,000	180	240
3/4-16	15,400	144	193	23,800	223	298	33,600	315	420
7/8-14	12,610	138	184	32,480	355	473	45,855	500	668
1-12	16,410	205	273	42,270	528	704	59,670	745	995

Clamp load estimated as 75% of proof load for specified bolts.

Torque values for 1/4 and 5/16 inch series are in inch-pounds. All other torque values are in foot-pounds.

Torque values calculated from formula $T = KDF$

where: $K=0.15$ for "lubricated" conditions

$K=0.20$ for "dry" conditions



LIMITED WARRANTY

Quick Attach Attachments LLC warrants each new machine manufactured by us to be free from defects in material and workmanship for a period of twenty-four (24) months from date of delivery to the original purchaser.

Our obligation under this warranty is to replace free of charge, at our factory or Direct Outlet locations, any part proven defective within the stated warranty time limit.

All parts must be returned freight prepaid and adequately packaged to prevent damage in transit.

This warranty does not cover:

1. New products which have been operated in excess of rated capacities or negligence
2. Misuse, abuse, accidents or damage due to improperly routed hoses
3. Machines which have been altered, modified or repaired in any manner not authorized by our company
4. Previously owned equipment
5. Any ground engaging tools in which natural wear is involved, i.e. tooth tips, cutting teeth, etc
6. Normal maintenance
7. Fork tines
8. Hydraulic motors that have been disassembled in any manner

In no event will the Sales Representative, Direct Outlet, Quick Attach Attachments LLC, or any other company affiliated with it or them be liable for incidental or consequential damages or injuries, including but not limited to the loss of profit, rental or substitute equipment or other commercial loss. Purchaser's sole and exclusive remedy being as provided here in above.

Quick Attach Attachments LLC must receive immediate notification of defect and no allowance will be made for repairs without our consent or approval.

This warranty is in lieu of all other warranties, express or implied by law or otherwise, and there is no warranty of merchantability or fitness purpose.

No agent, employee, or representative of Quick Attach Attachments LLC has any authority to bind Quick Attach Attachments LLC to any warranty except as specifically set forth herein. Any of these limitations excluded by local law shall be deemed deleted from this warranty; all other terms apply.

This warranty may not be enlarged or modified in any manner except in writing signed by an executive officer of Quick Attach Attachments LLC to improve its products whenever it is possible and practical to do so. Quick Attach Attachments LLC reserves the right to make changes and or add improvements at any time without incurring any obligation to make such changes or add such improvements to products previously sold.

Quick Attach Attachments LLC
P.O. Box 128 Alexandria, MN 56308
Phone (320) 759-1551 Fax (320) 759-1590

