

# **XTREME MOWER HD**

**Operator's Manual  
Maintenance & Parts Information**



**Read this Manual Before Use**

# TABLE OF CONTENTS

---

SAFETY	3-4
DECAL INFORMATION	5-7
MOUNTING INSTRUCTIONS	8-9
OPERATING INSTRUCTIONS	10-12
MAINTENANCE	13-15
PARTS INFORMATION	16-19
GENERAL SPECS	20
TORQUE INFORMATION	21
NOTES	22
WARRANTY	23

**NOTE:** Write your serial number for your attachment in the spaces below. Always refer to this serial number when calling for services parts.

---

**Serial Number**

---

**Attachment Dealer**

---

**Address**

---

**Phone Number**

---

**Contact**

**NOTE:** Quick Attach LLC reserves the right to make improvements in design or changes in specifications at any time without notice and without incurring any obligations to install them on units previously sold.

# SAFETY

---

**DO NOT use or perform maintenance on this machine until this manual has been read and understood. In addition, read the Operation and Maintenance Manual(s) pertaining to the attachment and the attachment carrier (“Loader”).**

The user is responsible for inspecting the machine daily, and for having parts repaired or replaced when continued use of the machine would cause damage, excessive wear to other parts or make the machine unsafe for continued operation.

If an operating procedure, tool device, maintenance or work method not specifically recommended is used; you must satisfy yourself that it is safe for you and others. You must also ensure that the attachment will not be damaged or made unsafe by the procedures you choose.

Quick Attach LLC cannot anticipate every possible circumstance that might involve potential hazard. The safety messages found in this manual and on the machine are therefore not all inclusive

The signal words **CAUTION**, **WARNING**, or **DANGER** are used to indicate hazards.

## **CAUTION**

Indicates a potentially hazardous situation which, if not avoided, may result in minor or moderate injury.

## **WARNING**

Indicates a potentially hazardous situation which, if not avoided, could result in death or serious injury.

## **DANGER**

Indicates a potentially hazardous situation which, if not avoided, will result in death or serious injury.

The word **IMPORTANT** is used in the text when immediate damage will occur due to improper technique or operation.

The word **NOTE** is used to convey information that is out of context with the manual text; special information such as specifications, techniques, reference information, and other information of a supplementary nature.

# SAFETY

---

## Improper operation can cause serious injury or death.

### PRE-OPERATION

- This attachment is designed for mowing grass, brush, and small trees only. **NEVER** use this attachment for purposes other than intended.
- Read the operator's manual for the "Skid Steer Loader". **NEVER** allow untrained people to operate.
- Operating instructions must be given to everyone before operating this machine and at least once a year thereafter in accordance with OSHA regulations.
- **NEVER** exceed the maximum recommended input power or speed specifications for the attachment. Overpowering or over-speeding the attachment may cause personal injury and/or machine damage.
- Keep all shields, guards, and covers in place.
- Do not modify equipment or add attachments that are not approved by Quick Attach LLC.
- Use adequate safety warning lights and devices as required by local regulations. Obey all local laws and regulations regarding machine operation on public property.

### OPERATION

- Always wear eye protection that meets z87.1 or use with a loader enclosure that provides similar protection.
- Hydraulic connections may be hot after use. Use gloves if connecting or disconnecting after use.
- Check and be sure all operating controls are in neutral before starting the engine.
- Keep people away from loader and attachment when in use. This attachment send objects flying and has rotating parts. **NEVER** direct discharge toward people - rocks and debris can be thrown hundreds of feet.

### OPERATION (continued)

- **NEVER** operate near embankments or terrain that is so steep that rollover could occur.
- Always stay in the operator position when using the attachment.
- Before leaving the operator position, disengage hydraulic drive, lower the attachment to rest flat on the ground, stop engine, set park brake, and wait for all motion to stop.
- **NEVER** place hands in the discharge chute or clear debris while engine is running.

### AVOID HIGH PRESSURE FLUIDS HAZARD

- Escaping fluid under pressure can penetrate the skin causing serious injury.
- Avoid the hazard by relieving the pressure before disconnecting hydraulic lines.
- Use a piece of paper or cardboard, **NOT BODY PARTS**, to check for suspected leaks. Wear protective gloves and safety glasses or goggles when servicing or performing maintenance on hydraulic systems.
- If an accident occurs, see a doctor immediately. Any fluid injected into the skin must be surgically removed within a few hours or gangrene may result.

### MAINTENANCE

- **NEVER** make adjustments, lubricate, clean, or perform any service on the machine while it is in operation.
- Make sure the attachment is serviced on a daily basis. Improper maintenance can cause serious injury or death in addition to damage to the attachment and/or your equipment.

# DECAL INFORMATION

## Serial Number Location:

It is important to refer to the serial number of your attachment when making repairs or ordering parts. Early or later models (identification made by serial number) may use different parts, or it may be necessary to use different procedures in doing a specific operation. Please see below for Serial Plate location.

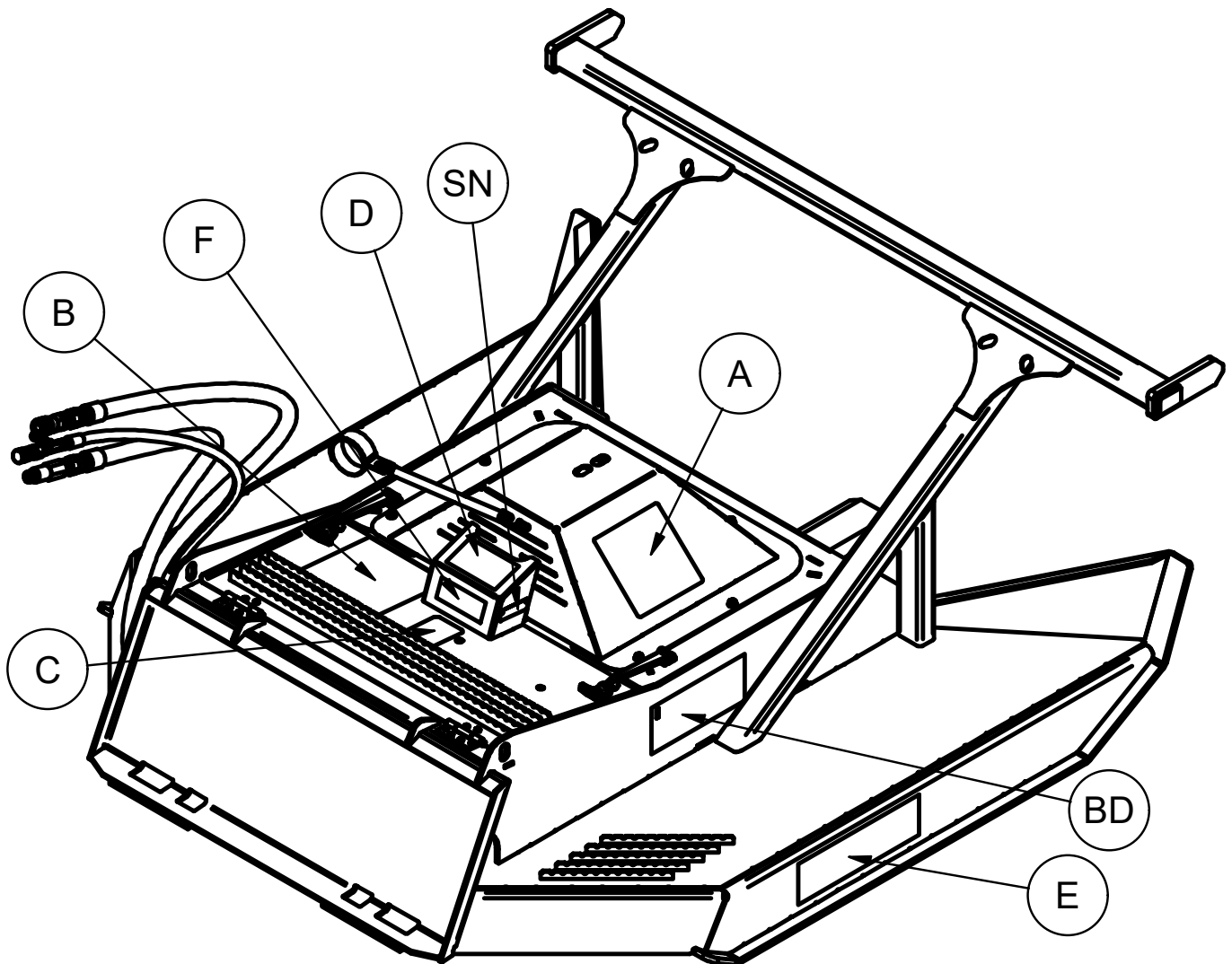

# DECAL INFORMATION

**A**



Part number: 316078  
 Location: On both sides of motor shield  
 Quantity: 1

**B**

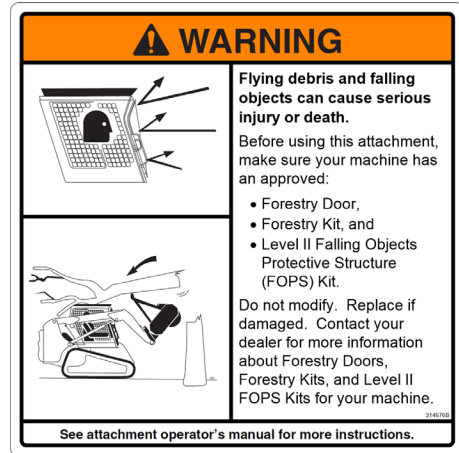

Part number: 314676  
 Location: Top of storage door  
 Quantity: 1

**C**



Part number: 200001  
 Location: Centered on top of storage door  
 Quantity: 1

**D**



Part number: 320359  
 Location: On storage door hose guard  
 Quantity: 1

## Safety Decals Locations:

The locations of the safety decals are shown. If these decals are missing, damaged, or painted over they must be replaced. Call Quick Attach LLC (320-759-1551) for replacement decals.

# DECAL INFORMATION

**E**



Part number: 400493  
Location: Outer sides of deck side plate  
Quantity: 2

**F**



Part number: 340883 OR 340884  
Location: Back side of hose guard  
Quantity: 1

**BD**



Brand Decal: Large  
Location: Both Ribs and front of motor shield  
Quantity: 3

## Safety Decals Locations:

The locations of the safety decals are shown. If these decals are missing, damaged, or painted over they must be replaced. Call Quick Attach LLC (320-759-1551) for replacement decals.

# MOUNTING INSTRUCTIONS

---

After the initial set-up assembly is completed use the following procedure to mount the attachment to the loader for user operation.

## **⚠ WARNING**

**Coupler wedges or pins must extend through holes in attachment. Levers must be fully down and locked. Failure to secure wedges or pins can allow the attachment to come off and cause injury or death.**

1. Use the step, safety treads, and grab handles to get on and off the loader and attachment.
2. Sitting in the operator's seat, lower seat bar and fasten the seat belt.
3. Drive the loader to the rear of the attachment. Put the loader quick attach coupler into the attachment mounting bracket.
4. Tilt the loader coupler backward a small amount until it is fully engaged in the brush mower mounting bracket.
5. If you have manual levers, stop the engine, and engage the park brake. If not, proceed to step 6.
6. Secure the coupler locking mechanism that attaches the attachment to the loader.
7. Connect the hydraulic quick couplers from the attachment to the loader.

**IMPORTANT:** You must connect the small, third hose which is the case drain hose, or you will permanently damage the hydraulic motor.

**NOTE:** See the loader's operator's manual for further instructions.

**NOTE:** Attachment is shipped with 16FJX (1-5/16" Female JIC swivel) fittings on the ends of the lead hoses and 8FJX (3/4" Female JIC swivel) on the case drain hose.

**IMPORTANT:** Wipe the ends of the hydraulic quick couplers (both lead and loader) with a rag to remove any possible contamination. Contamination can cause hydraulic components to fail and is not covered under warranty.

**IMPORTANT:** Make sure the quick couplers are fully engaged. If the quick couplers do not fully engage, check to see that the couplers are the same size and brand. Do not force the quick couplers together.



# MOUNTING INSTRUCTIONS

8. Make sure the hoses are properly routed to fit your specific loader. If the hoses are not routed correctly, hoses may get pinched or rub on tires or tracks. Be sure to check the hose routing through the full range of intended motion of the attachment before operating it. More than one routing may be acceptable depending on the loader. Pick the routing that best suits your loader.

**IMPORTANT:** Proper hose routing is the responsibility of the owner and/or operator. Pinched or stretched hoses are not covered under warranty.

9. Mounting is now complete and you are ready to use the attachment. Use reverse order of above instructions to dismantle the attachment from the loader.

**NOTE:** Make sure the pressurized hose is routed to the pressure port of the motor valve block. If it isn't, the attachment will not operate properly. The proper hose to pressurize has **PRESSURE** printed on the outer cover and/or a red cable tie on the end.

If you are operating the loader controls correctly and the mower still does not work, try switching the hydraulic couplers around on the mower lead hoses. This will effectively reverse the flow to the motor.

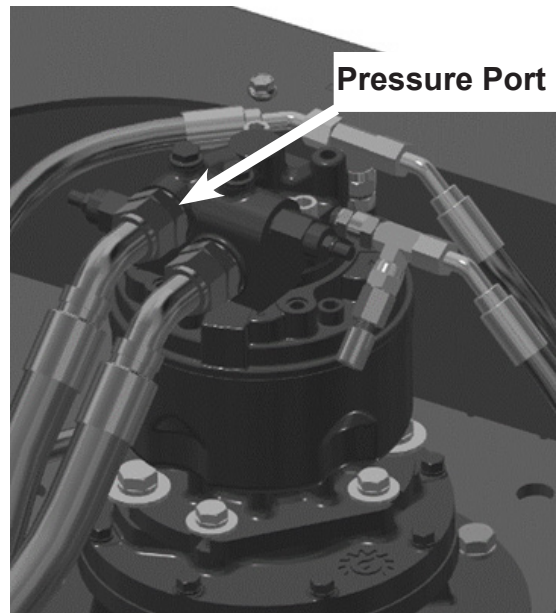

# OPERATING INSTRUCTIONS

**⚠ WARNING** To avoid serious injury or death, keep people away from the loader and attachment when in use. The attachment can drop trees and limbs in unpredictable directions. Make sure there are no people, power lines, buildings, or other objects that could be in the fell zone. Never cut trees that could fall into these objects. Loader must be equipped with approved Forestry Door, Forestry Kit, and Level II Falling Object Protective Structure (FOPS) Kit.

**IMPORTANT:** Before operating the attachment, perform the service schedule for routine maintenance.

**IMPORTANT:** Certain materials can wrap around parts of the attachment or cause other damage. Avoid contacting materials like metal wire, hoses, ropes, tarps, mattresses, rugs, or plastics.

**IMPORTANT:** Certain land features can cause damage. Inspect the cutting area and avoid obstructions like drop offs, holes, rocks, debris, etc.

1. With the operator in the seat of the loader, the seat belt fastened, and the seat bar lowered (if so equipped), start the engine.
2. With the loader boom lowered completely, mower deck tipped back 0 to 10 degrees and engine at low idle, activate the auxiliary hydraulic system to start the disc rotation. Make sure auxiliary hydraulic circuit is operating in the High Flow mode and flow is in the proper direction.

**IMPORTANT:** The attachment is designed to operate from 25 to 45 gpm. There are two motor options to optimize the blade speed. Running the lower range flow rate motor at the higher flow rates may cause damage to the motor and will void the warranty. Running the higher flow range motor at low flow ranges may decrease performance.

**IMPORTANT:** Do not operate the attachment if excessive vibration is present or serious damage can occur. Check to make sure that there is not debris lodged between the teeth, wrapped around the blades or on top of the blade carrier.



**IMPORTANT:** To prevent hydraulic system damage when operating in temperatures below 40°F, allow attachment to run with engine at idle for at least 10 minutes to warm oil before slowly increasing to operating speed.

**NOTE:** Certain loaders may not operate in high flow mode without a special wire harness. Others require the control switches to be operated in a specific way. It may also be necessary to switch the hose couplers around to match your loader. (See loader's operator's manual)

# OPERATING INSTRUCTIONS

## Mowing grass and small brush

1. Once the disc is spinning at full RPM adjust the position of the mower so that the front of the skid plates are resting on or slightly above the ground while the back of the mower is slightly higher (1-3").
2. Slowly drive the loader forward into the work area, adjusting travel speed as the vegetation changes density, to maintain proper blade speed. The mower may need to be raised slightly to make sharp turns.

**NOTE:** If small brush or grass begin to accumulate on top of the blade carrier, back up slowly to allow it to fall to the ground, then proceed as before

3. If further mulching of debris is needed, back-drag over the area previously cut keeping the mower in the same position (front of mower slightly tilted forward), to mulch driving forward tilt the front of the mower up while keeping the back on the ground and slowly drive forward. Repeat the process until the debris is to the desired size.

**NOTE:** The type and thickness of the material being cut, available horsepower and the ground conditions will determine the best ground speed and cutting procedure.

**IMPORTANT:** Lifting the back of the mower higher than 2-3" may cause debris to be thrown back toward the operator.

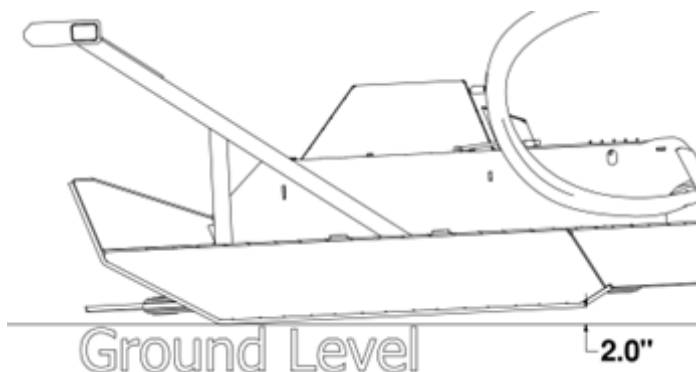

## Mowing large brush, clumps of brush, and small trees

1. Once the disc is spinning at full RPM, adjust the position of the mower so that the back of the skid shoes are resting on the ground, then tilt the front of the mower up from 0-24" as needed.

**NOTE:** The angle of the mower as well as the location of the material being cut in relation to the mower will determine the amount of force exerted by the push-bar. The more the mower is angled up the less contact the push-bar will have, cutting in the center or toward an edge of the mower will also affect the amount of contact the push-bar has with the material being cut.

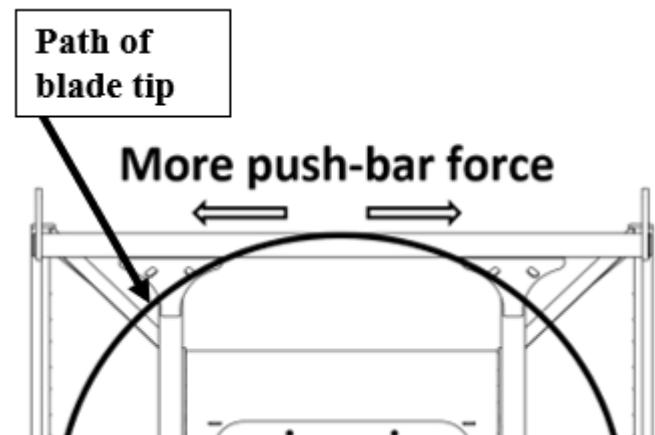

2. Slowly drive into the material you are cutting while adjusting the angle and height of the deck as needed keeping pressure with the push-bar to topple the brush or tree where desired.
3. Once the material is on the ground the stump can be left as is or cut lower using the blades or the optional stump grinder teeth.
4. The fallen tree or brush can be left whole or further mulched by driving slowly into it with the back of the mower on the ground and the front tilted upward and/or back-dragging with the front of the mower on the ground with the back slight off the ground. Repeating until the debris is to the desired size.

# OPERATING INSTRUCTIONS

## Mowing larger trees (up to 10")

1. Once the disc is spinning at full RPM adjust the position of the mower so that the skid plates are parallel to the ground.
2. Drive slowly into the tree to begin cutting, the tree can either be cut close to the ground or higher if desired.

**NOTE:** The angle of the mower as well as the location of the material being cut in relation to the mower will determine the amount of force exerted by the push-bar. The more the mower is angled up the less contact the push-bar will have, cutting in the center or toward an edge of the mower will also affect the amount of contact the push-bar has with the material being cut.

**⚠ WARNING** Trees can fall in any direction, it is the responsibility of the operator to ensure the area around the tree is clear of people, animals, or anything that could be damaged. It is also the operator's responsibility to inspect trees before cutting to try and determine where they may fall once cut and position themselves accordingly.

3. Once the tree is on the ground the stump can either be left or ground down further using the stump grinder teeth on the bottom of the blade carrier.
4. The tree itself can also be left or further mulched using the stump grinder teeth to grind up larger material while the smaller material can be mulched by driving forward with the back of the mower on the ground and the front of the mower slightly raised or back-dragging with the front of the mower on the ground and the back of the mower lightly raised, repeating until the debris is to the desired size

**IMPORTANT:** While this attachment has been designed to handle the extreme loads associated with cutting grass, brush, and trees up to 10", every machine has its limits. Due to the large amount of spinning mass, high rotational speed of the disc, and varieties of trees to cut the operator must use care not to attempt cutting any tree with a trunk larger than 10" diameter or travel too fast while cutting large trees and brush, as this could overload the spindle. Any spindle damage is considered to be the result of operator abuse and is not covered under warranty.





# ROUTINE MAINTENANCE

## **⚠ WARNING**

Lower the attachment to rest flat on the ground, shut down the engine, relieve the hydraulic pressure to the attachment, set the park brake, and wait for all motion to stop before leaving the operator's seat to perform service of any kind.

It is the operator's responsibility to make daily inspections of the loader and attachment for damage, loose bolts, fluid leaks, or anything else that could cause a potential service or safety problem. Preventive maintenance is the easiest and least expensive type of maintenance.

**IMPORTANT:** Bolts can loosen after initial usage. After the first hour of operation check all bolts.

## DAILY INSPECTION

Follow the rotary cutter service schedule for routine maintenance.



Check the following items every 4 hours of operation:

1. Check blades for cracks or excessive damage. Replace if necessary.
2. Check blade bolt for proper torque of 240 ft-lb (325 N-m)
3. Check entire attachment for weld cracks or excessive damage. Replace if necessary.
4. Check stump grinder teeth for proper torque of 240ft.-lbs. (325Nm).
5. Check all hardware. Retighten if necessary.
6. Check shields. Repair if damaged or replace if necessary.
7. Check for damaged or missing decals. Replace if damaged or missing.
8. Check for damaged or leaking hydraulic hoses or fittings. Replace or tighten.
9. Clean debris, leaves, grass, and flammable material from main frame area and under covers.

Change the bearing carrier oil after the first 50 hours of operation. Change the oil annually or every 500 hours of operation thereafter, whichever comes first.

### Recommended ambient and operating temperatures for conventional and synthetic gear lubricants

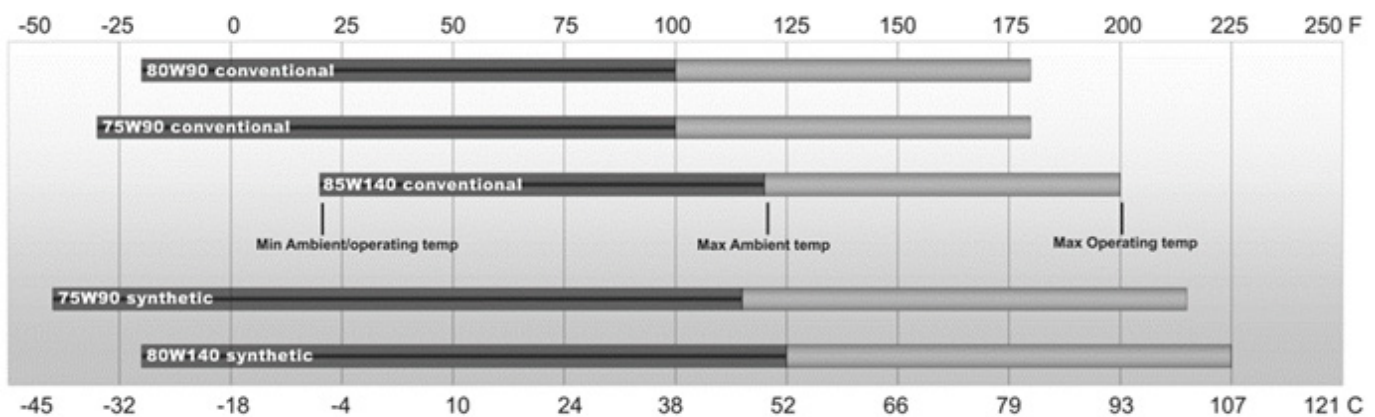

Note: Ambient temperature is the air temperature measured in the immediate vicinity of the gearbox. A Gearbox exposed to the direct rays of the sun or other radiant heat sources will operate at higher temperatures and therefore must be given special consideration. The max operating temperature must not be exceeded under any circumstances, regardless of ambient temperature.

# ROUTINE MAINTENANCE

## Changing Gearbox Oil

1. Lower the deck to the ground, stop the engine, engage the parking brake, and exit the loader.
2. Remove the motor cover by taking the (6) bolts out and lifting it off the mower. Locate the drain hose for the gear box for later use.
3. Enter the loader and raise the mower up while slowly tilting the front down to be as vertical as possible.
4. Have another person engage the loader arm safety lock. (Check loader operator's manual for proper engagement)
5. With mower vertical you can now drain the oil from the gearbox by removing the plug on the end of the drain hose as well as the fill plug on the top of the gearbox.
6. Once the oil is completely drained, tighten the plug back into the drain hose.
7. Have another person remove the lift arm safety locks and lower the attachment to sit flat on level ground, stop the engine, engage parking brake, and exit loader.
8. Remove the plug from the top fill hole and add 17 oz of the appropriate oil type. Tighten the plug back into the gearbox cover. (See picture on bottom of page 15)
9. Reinstall motor cover when complete.

## Cleaning the Attachment

1. Position the attachment flat on the ground.
2. Remove the top shields to access the motor cavities.
3. Use low pressure water or a small brush to remove any unwanted dirt and debris.

**⚠ WARNING** Use care when removing any debris wrapped around the teeth or disc. Disc can rotate suddenly.

4. Reinstall shields when complete.

## Replacing the Blades

**⚠ CAUTION** New and used blades can be sharp. Wear gloves to protect your hands.

1. Position the attachment flat on the ground, stop the engine, engage the parking brake, and exit loader.
2. Disconnect the lead hoses from the loader and connect them together so that the blade will spin freely by hand.
3. Rotate the blade carrier so that a blade is in the front of the mower. Remove the (3) 5/8" bolts from the blade

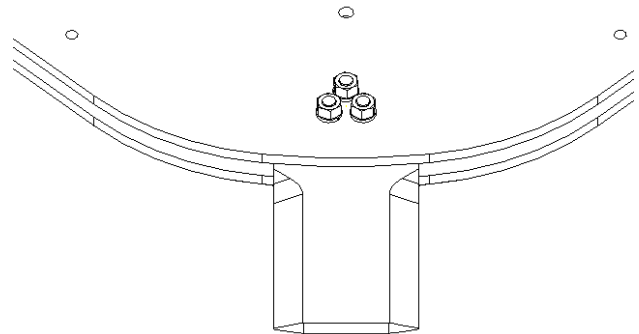

4. Remove the blade and bushing  
**NOTE:** If the blade doesn't slide out use 1 or 2 of the 5/8 bolts and nuts to spread the blade carrier.  
**NOTE:** The blades can be rotated to use both sides before being replaced (two will face down and two will face up on opposing sides of the blade carrier)  
**NOTE:** When flipping the blades over, turn the bushing 120 degrees as well to increase the longevity.
5. Replace blades and bushings, torquing the bolts to 240 ft-lb. It is recommended that Loctite is applied to the bolt threads before replacing.
6. Repeat procedure until all (4) blades have been replaced or turned.

**NOTE:** Replace the bolts, nuts, and bushings with new ones whenever you place new blades on the attachment. Replace all (4) blades at the same time.

# ROUTINE MAINTENANCE

## Replacing/Rotating Stump Grinder Teeth

**⚠ CAUTION** New and used teeth can be sharp. Wear gloves to protect your hands.

**NOTE:** The outer teeth will wear faster than those closer to the center. The teeth can be swapped from the inside to out. Make sure that opposing teeth on the blade carrier are replaced/rotated together for balancing.

1. Using blocks, lower the loader arms as low as they will go and position the blocks so that the front of the skid shoes rest on them lifting the front of the mower off the ground, stop the engine, engage the park brake, and exit the loader.
2. Disconnect the lead hoses from the loader and connect them together so that the blade will spin freely by hand.
3. Using a wrench loosen the nuts on top of the blade carrier and remove the teeth as desired.
4. To replace the teeth place them in the nest on the blade carrier ensuring they are positioned correctly for the rotation of the disc, the carbide cutting tip should face the direction of rotation. Tighten the nut on top, torquing to 240 ft-lb.

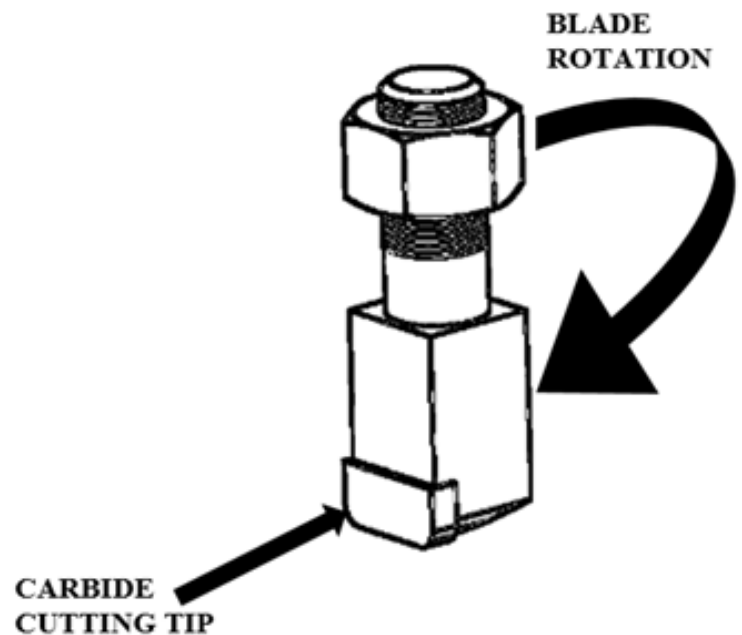
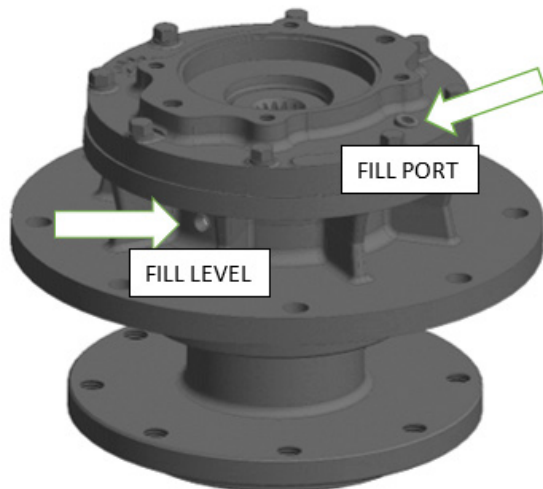
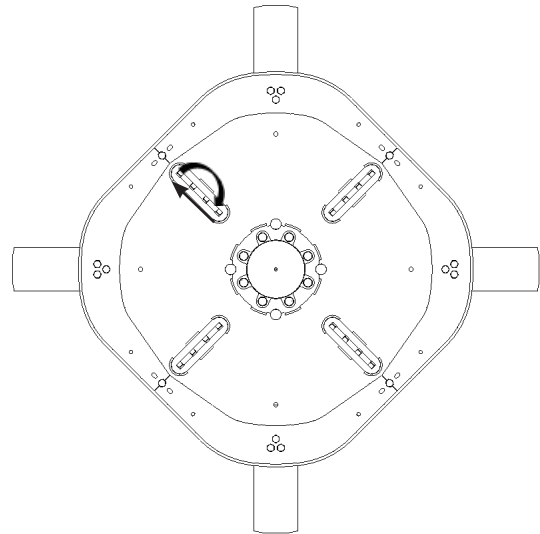

# PARTS INFORMATION

ITEM	QTY	PART NUMBER	DESCRIPTION	STOCK NO.
1	1	340800	DECK EXTREME HD MOWER W/A	
2	1	340803	COVER STORAGE W/A	
3	1	340809	COVER MOTOR W/A	
4	6	19929	BOLT	3/8 X 3/4 NC FLG
5	2	340318	LATCH RUBBER 10.5 W/BRACKET	
6	10	41125	RIVET 3/16 STEEL #64	
7	16	13003	BOLT HEX	1/4 X .75 UNC Z
8	18	37210	NUT HEX	1/4 NC
12	2	340319	HINGE STRAP 4.25 WIDE 8 BOLT	
13	1	330864	HOLDER MANUAL CANISTER 12.5 X 2.25	
14	2	21151	BOLT CARRIAGE	1/4 X 1/2 UNC Z
15	1	340334	STRAP ELASTIC 12"	
16	1	340335	STRAP HANGING CINCH 3.8-5.1 OD	
17	1	340848	CARRIER BEARING MODEL-132 14T-C	
18	8	0167019	NUT FLG TOP-LOCK	5/8 UNF Z GR 8
20	8	18963	BOLT HEX	5/8 X 2.75 UNF GR8 Z
21	10	33897	WASHER SPLIT LOCK	5/8 GR8 Z
22	1	340887	MOTOR 7.87 FS15 14 TOOTH SAE (130CC)	
29	1	331404	O-RING 5" ID X 9/64 (-250)	
39	4	15209	BOLT HEX	1/2 X 1-1/2 UNC GR8 Z
41	4	33895	WASHER SPLIT LOCK	1/2 GR8 Z
42	2	33863	WASHER FLAT	5/8 GR8 Z
43	4	33861	WASHER FLAT	1/2 GR 8 Z



# PARTS INFORMATION

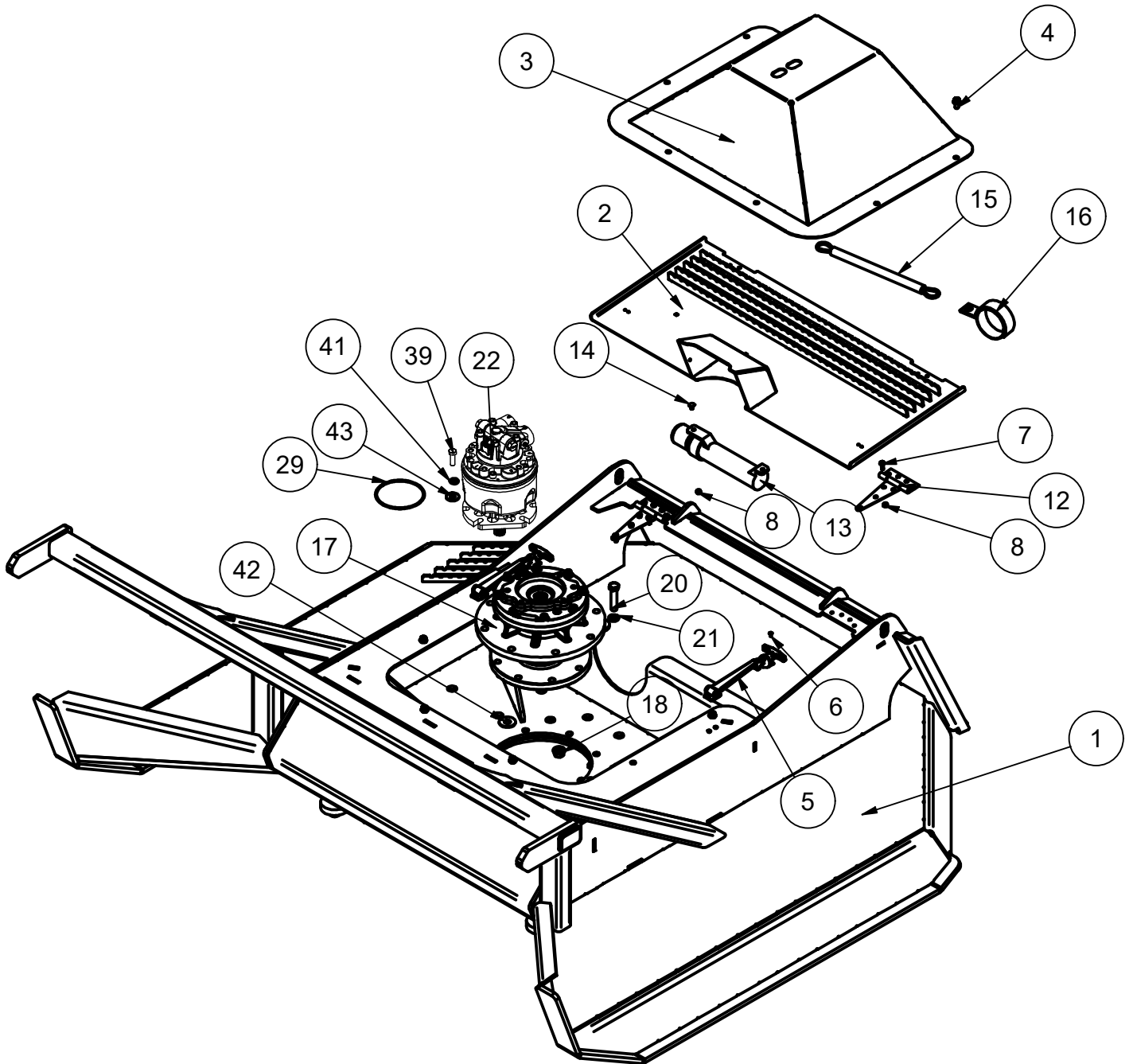

# PARTS INFORMATION

ITEM	QTY	PART NUMBER	DESCRIPTION	STOCK NO.
17	1	340848	CARRIER BEARING MODEL-132 14T-C	
19	8	33898	WASHER LOCK	3/4 GR8
21	16	33897	WASHER SPLIT LOCK	5/8 GR8 Z
30	4	340856	BLADE .63 X 6 X 15.75 DB	
31	4	340869	BUSHING BLADE SPACER	
32	16	421966	TOOTH CARBIDE 3SG	
33	16	37312	NUT HEX	TOP LOCK 5/8 UNF GR8
34	16	36464	NUT HEX	5/8 UNF GR8
35	1	331229	CARRIER BLADE BOTTOM W/A	
36	1	331238	CARRIER BLADE TOP W/A	
37	8	15365	BOLT HEX	3/4 X 3 UNC GR8
38	16	18962	BOLT HEX	5/8 X 2-1/2 UNF GR8

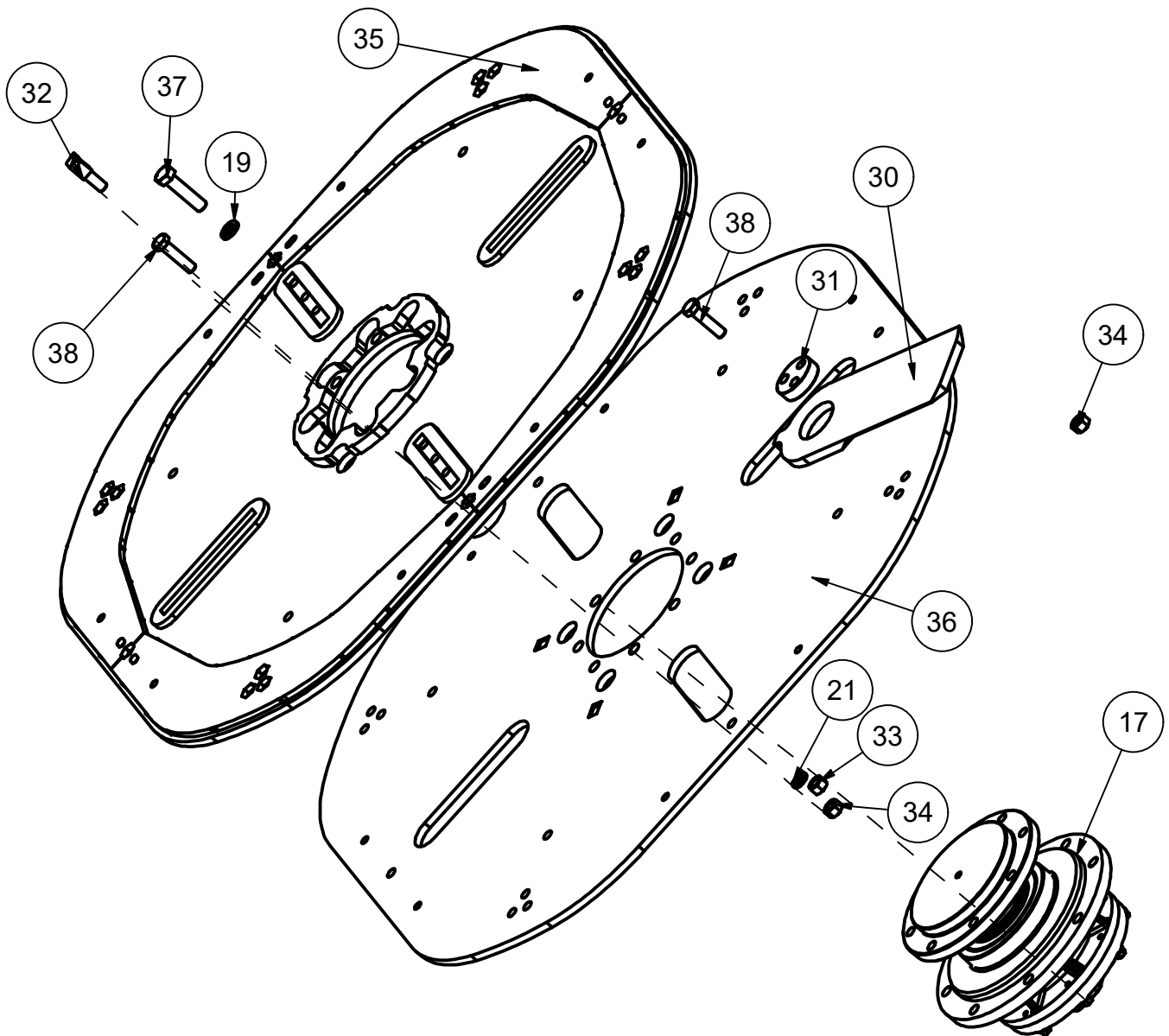

# PARTS INFORMATION

ITEM	QTY	PART NUMBER	DESCRIPTION	STOCK NO.
9	1	330933	HOSE 3/8" X 24" 6FJX- 6FJX-90	GEARBOX
10	2	340854	HOSE 1" X 108" 16FJX-16FJX-45	LEAD
11	1	340898	HOSE 1/2" X 120" 8FJX-6FJX-90	CASE DRAIN
23	1	320063	ADPT PLUG 6MJ	GEARBOX
24	1	201528	ADPT STR 16MB-16MJ	TO PORT B
25	1	331346	ADPT STR 16MB-16MJ CHECK 5PSI-3000PSI	TO PORT A
26	1	330886	ADPT STR 4MP-6MJ LONG	GEARBOX
27	1	319476	ADPT STR 4MBSPP-6MJ	CASE DRAIN
28	1	330990	ADPT TEE 8FJX-8MJ-4FP	CASE DRAIN
44	1	331384	ADPT STR 4MP RELIEF 225 PSI	CASE DRAIN

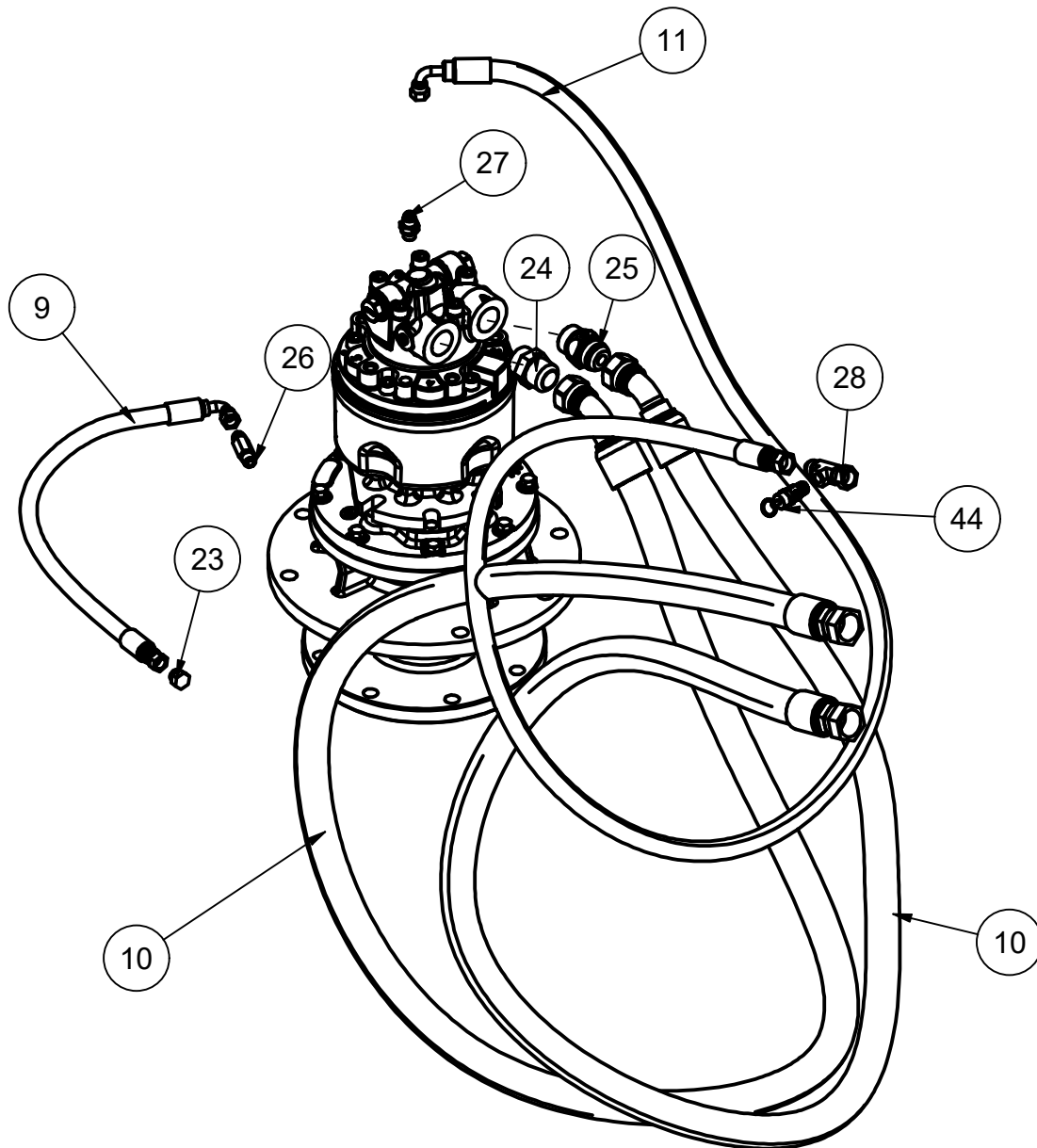

# GENERAL SPECS

Model	72" (25.0-31.9 gpm)	72" (32.0-45.0 gpm)
Overall Height	36"	
Overall Length	85"	
Overall Width	78.9"	
Cutting Width	72"	
Deck Thickness/Material	1/4" Grade 50 Steel	
Skid Shoe Thickness/Material	1/2" AR400 Steel	
Output Shaft Diameter	3.25"	
Operating Weight w/ Blade Carrier	2,300 lb.	
Flow Rates	25 - 45 GPM High Flow Only	
Tip Speed	15,700 ft/min @ 30 GPM	15,500 ft/min @ 40 GPM
Operating Pressure	3,000 - 4,200 psi	
Storage Compartment Dimensions	39.8" Wide x 18.8" Long x 9" Deep	
Blades	(4) 5/8" x 6" x 15.75" Straight Blades	
Blade Material	AR400	
Blade Carrier Weight	697 lb.	
Stump Grinder Teeth	(16) 3/4" Carbide Tipped	
Cutting Capacity	10" Soft Wood	

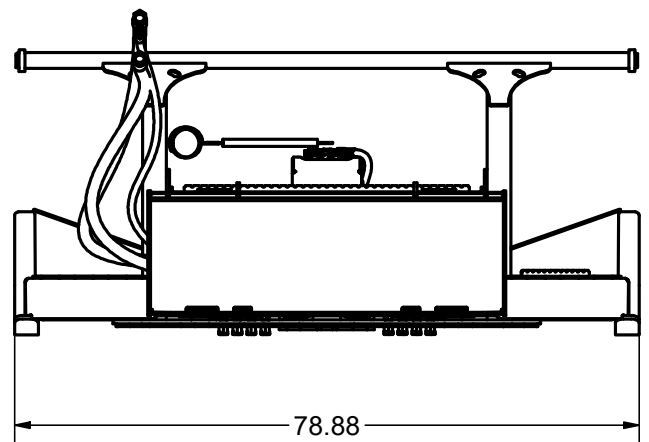
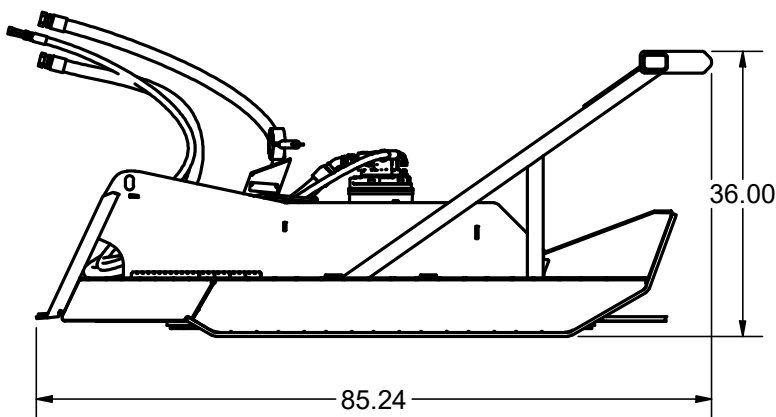

# TORQUE INFORMATION

## Torque-Tension Relationships for SAE J429 Grade Bolts

Nominal Thread Size	SAE J429 Grade 2			SAE J429 Grade 5			SAE J429 Grade 8		
	Clamp Load (lbs)	Tightening Torque		Clamp Load (lbs)	Tightening Torque		Clamp Load (lbs)	Tightening Torque	
		K = .15	K = .20		K = .15	K = .20		K = .15	K = .20
<b>Unified Coarse Thread Series</b>									
1/4-20	1,300	49 in-lbs	65 in-lbs	2,000	75 in-lbs	100 in-lbs	2,850	107 in-lbs	143 in-lbs
5/16-18	2,150	101	134	3,350	157	210	4700	220	305
3/8-16	3,200	15 ft-lbs	20 ft-lbs	4,950	23 ft-lbs	31 ft-lbs	6,950	32.5 ft-lbs	44 ft-lbs
7/16-14	4,400	24	30	6,800	37	50	9,600	53	70
1/2-13	5,850	36.5	49	9,050	57	75	12,800	80	107
9/16-12	7,500	53	70	11,600	82	109	16,400	115	154
5/8-11	9,300	73	97	14,500	113	151	20,300	159	211
3/4-10	13,800	129	173	21,300	200	266	30,100	282	376
7/8-9	11,425	125	166	29,435	321	430	41,550	454	606
1-8	15,000	187.5	250	38,600	482.5	640	54,540	680	900
<b>Unified Fine Thread Series</b>									
1/4-28	1,500	55 in-lbs	75 in-lbs	2,300	85 in-lbs	115 in-lbs	3,250	120 in-lbs	163 in-lbs
5/16-24	2,400	112	150	3,700	173	230	5,200	245	325
3/8-24	3,600	17 ft-lbs	22.5 ft-lbs	5,600	26 ft-lbs	35 ft-lbs	7,900	37 ft-lbs	50 ft-lbs
7/16-20	4,900	27	36	7,550	42	55	10,700	59	78
1/2-20	6,600	41	55	10,200	64	85	14,400	90	120
9/16-18	8,400	59	79	13,000	92	122	18,300	129	172
5/8-18	10,600	83	110	16,300	128	170	23,000	180	240
3/4-16	15,400	144	193	23,800	223	298	33,600	315	420
7/8-14	12,610	138	184	32,480	355	473	45,855	500	668
1-12	16,410	205	273	42,270	528	704	59,670	745	995

Clamp load estimated as 75% of proof load for specified bolts.

Torque values for 1/4 and 5/16 inch series are in inch-pounds. All other torque values are in foot-pounds.

Torque values calculated from formula  $T = KDF$

where: K=0.15 for "lubricated" conditions

K=0.20 for "dry" conditions





## **LIMITED WARRANTY**

Quick Attach Attachments, LLC warrants each new machine manufactured by us to be free from defects in material and workmanship for a period of twenty-four (24) months from date of delivery to the original purchaser.

Our obligation under this warranty is to replace free of charge, at our factory or Direct Outlet locations, any part proven defective within the stated warranty time limit.

All parts must be returned freight prepaid and adequately packaged to prevent damage in transit.

This warranty does not cover:

1. New products which have been operated in excess of rated capacities or negligence
2. Misuse, abuse, accidents or damage due to improperly routed hoses
3. Machines which have been altered, modified or repaired in any manner not authorized by our company
4. Previously owned equipment
5. Any ground engaging tools in which natural wear is involved, i.e. tooth tips, cutting teeth, etc
6. Normal maintenance
7. Fork tines
8. Hydraulic motors that have been disassembled in any manner

In no event will the Sales Representative, Direct Outlet, Quick Attach Attachments, LLC, or any other company affiliated with it or them be liable for incidental or consequential damages or injuries, including but not limited to the loss of profit, rental or substitute equipment or other commercial loss. Purchaser's sole and exclusive remedy being as provided here in above.

Quick Attach Attachments, LLC must receive immediate notification of defect and no allowance will be made for repairs without our consent or approval.

This warranty is in lieu of all other warranties, express or implied by law or otherwise, and there is no warranty of merchantability or fitness purpose.

No agent, employee, or representative of Quick Attach Attachments, LLC has any authority to bind Quick Attach Attachments, LLC to any warranty except as specifically set forth herein. Any of these limitations excluded by local law shall be deemed deleted from this warranty; all other terms apply.

This warranty may not be enlarged or modified in any manner except in writing signed by an executive officer of Quick Attach Attachments, LLC to improve its products whenever it is possible and practical to do so. Quick Attach Attachments, LLC reserves the right to make changes and or add improvements at any time without incurring any obligation to make such changes or add such improvements to products previously sold.

Quick Attach Attachments, LLC  
P.O. Box 128 Alexandria, MN 56308  
Phone (320) 759-1551  
Fax (320) 759-1590

