

LANDSCAPE RAKE V2

Operator's Manual

Maintenance & Parts Information



Read this Manual Before Use

TABLE OF CONTENTS

SAFETY	3-4
DECAL INFORMATION	5-6
MOUNTING INSTRUCTIONS	7-8
OPERATING INSTRUCTIONS	9-10
MAINTENANCE	11-15
TORQUE INFORMATION	16
PARTS INFORMATION	17-20
GENERAL SPECS	21
NOTES	22
WARRANTY	23

NOTE: Write your serial number for your attachment in the spaces below. Always refer to this serial number when calling for services parts.

Serial Number

Attachment Dealer

Address

Phone Number

Contact

NOTE: Quick Attach LLC reserves the right to make improvements in design or changes in specifications at any time without notice and without incurring any obligations to install them on units previously sold.

SAFETY

DO NOT use or perform maintenance on this machine until this manual has been read and understood. In addition, read the Operation and Maintenance Manual(s) pertaining to the attachment and the attachment carrier (“Loader”).

The user is responsible for inspecting the machine daily, and for having parts repaired or replaced when continued use of the machine would cause damage, excessive wear to other parts or make the machine unsafe for continued operation.

If an operating procedure, tool device, maintenance or work method not specifically recommended is used; you must satisfy yourself that it is safe for you and others. You must also ensure that the attachment will not be damaged or made unsafe by the procedures you choose.

Quick Attach LLC cannot anticipate every possible circumstance that might involve potential hazard. The safety messages found in this manual and on the machine are therefore not all inclusive.

The signal words **CAUTION**, **WARNING**, or **DANGER** are used to indicate hazards.

CAUTION

Indicates a potentially hazardous situation which, if not avoided, may result in minor or moderate injury.

WARNING

Indicates a potentially hazardous situation which, if not avoided, could result in death or serious injury.

DANGER

Indicates a potentially hazardous situation which, if not avoided, will result in death or serious injury.

The word **IMPORTANT** is used in the text when immediate damage will occur due to improper technique or operation.

The word **NOTE** is used to convey information that is out of context with the manual text; special information such as specifications, techniques, reference information, and other information of a supplementary nature.

SAFETY

Improper operation can cause serious injury or death.

PRE-OPERATION

- **NEVER** use this attachment for purposes other than intended.
- Read the operator's manual for the "Skid Steer Loader". **NEVER** allow untrained people to operate.
- Operating instructions must be given to everyone before operating this machine and at least once a year thereafter in accordance with OSHA regulations.
- **NEVER** exceed the maximum recommended input power or speed specifications for the attachment. Over-powering or over-speeding the attachment may cause personal injury and/or machine damage.
- Keep all shields, guards, and covers in place.
- Do not modify equipment or add attachments that are not approved by Quick Attach LLC.
- Use adequate safety warning lights and devices as required by local regulations. Obey all local laws and regulations regarding machine operation on public property.

OPERATION

- Always wear eye protection that meets z87.1 or use with a loader enclosure that provides similar protection.
- Hydraulic connections may be hot after use. Use gloves if connecting or disconnecting after use.
- Check and be sure all operating controls are in neutral before starting the engine.

OPERATION (continued)

- **NEVER** operate near embankments or terrain that is so steep that rollover could occur.
- Always stay in the operator position when using the attachment.
- Before leaving the operators position, disengage hydraulic drive, lower the attachment to rest flat on the ground, stop engine, set park brake, and wait for all motion to stop.

AVOID HIGH PRESSURE FLUIDS HAZARD

- Escaping fluid under pressure can penetrate the skin causing serious injury.
- Avoid the hazard by relieving the pressure before disconnecting hydraulic lines.
- Use a piece of paper or cardboard, **NOT BODY PARTS**, to check for suspected leaks. Wear protective gloves and safety glasses or goggles when servicing or performing maintenance on hydraulic systems.
- If an accident occurs, see a doctor immediately. Any fluid injected into the skin must be surgically removed within a few hours or gangrene may result.

MAINTENANCE

- **NEVER** make adjustments, lubricate, clean, or perform any service on the machine while it is in operation.
- Make sure the attachment is serviced on a daily basis. Improper maintenance can cause serious injury or death in addition to damage to the attachment and/or your equipment.

DECAL INFORMATION

Serial Number Location:

It is important to refer to the serial number of your attachment when making repairs or ordering parts. Early or later models (identification made by serial number) may use different parts, or it may be necessary to use different procedures in doing a specific operation. Please see below for Serial Plate location.

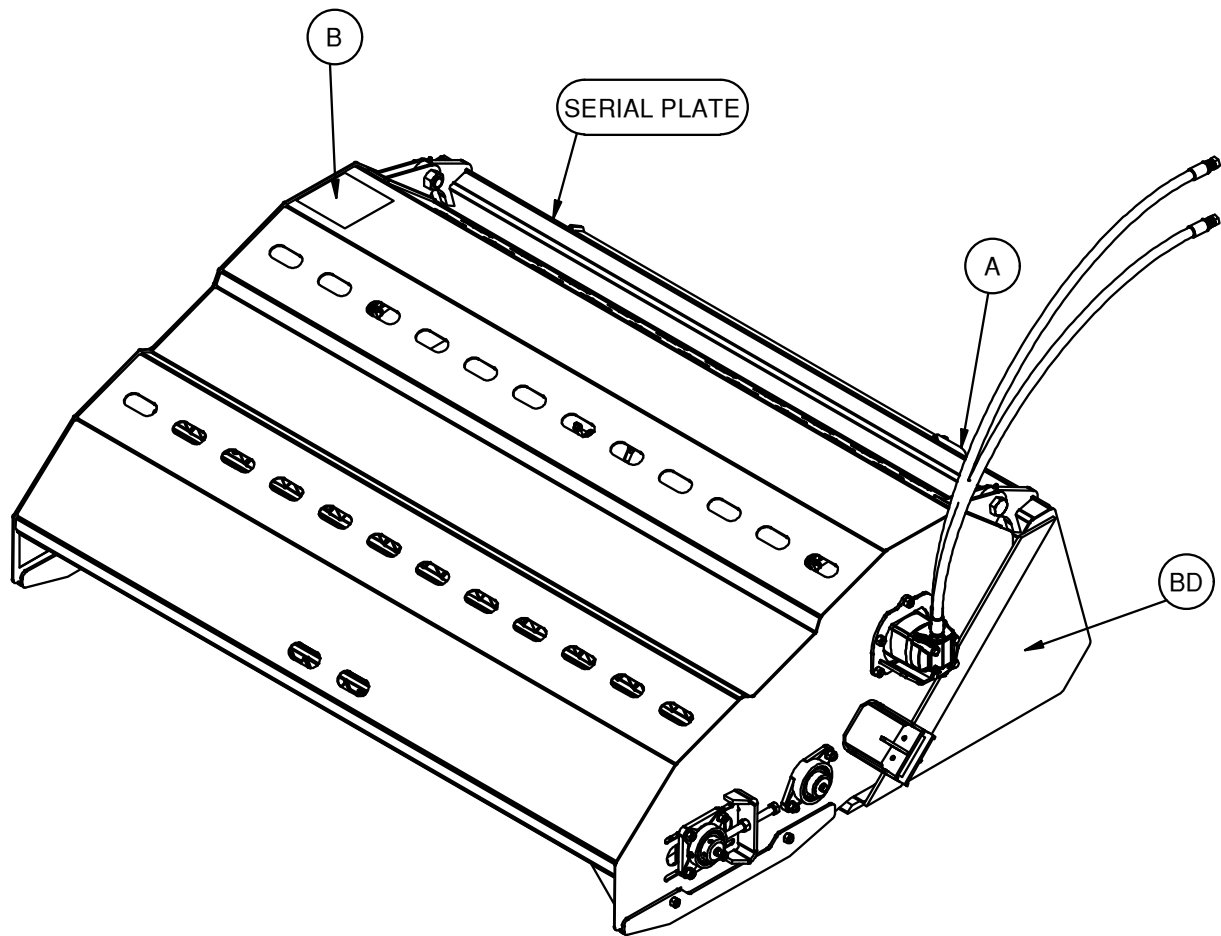

DECAL INFORMATION

A



Part number: 200001
Location: Back top left of mounting plate
Quantity: 1

B



Part number: 318289
Location: Top right side of body
Quantity: 1

BD



Brand Decal: Small
Location: On each end plate of bucket
Quantity: 2

Safety Decals Locations:

The locations of the safety decals are shown. If these decals are missing, damaged, or painted over they must be replaced. Call Quick Attach LLC (320-759-1551) for replacement decals.

MOUNTING INSTRUCTIONS

After the initial set-up assembly is completed use the following procedure to mount the attachment to the loader for user operation.

⚠ WARNING

Coupler wedges or pins must extend through holes in attachment. Levers must be fully down and locked. Failure to secure wedges or pins can allow the attachment to come off and cause injury or death.



1. Use the step, safety treads, and grab handles to get on and off the loader and attachment.
2. Sitting in the operator's seat, lower seat bar (if so equipped) and fasten the seat belt.
3. Drive the loader to the rear of the attachment. Put the loader quick attach coupler into the attachment mounting bracket.
4. Tilt the loader coupler backward a small amount until it is fully engaged in the attachment mounting bracket.
5. Stop the engine and engage the park brake.
6. Secure the coupler locking mechanism that attaches the attachment to the loader.
7. Connect the hydraulic quick couplers from the attachment to the loader.
8. Make sure the hoses are properly routed to fit your specific loader. If the hoses are not routed correctly, hoses may get pinched or rub on tires. Be sure to check the hose routing through the full range of intended motion of the attachment before operating it.

MOUNTING INSTRUCTIONS

IMPORTANT: Wipe the ends of the hydraulic quick couplers (both lead and loader) with a rag to remove any possible contamination. Contamination can cause hydraulic components to fail and is not covered under warranty.

IMPORTANT: Make sure the quick couplers are fully engaged. If the quick couplers do not fully engage, check to see that the couplers are the same size and brand. Do not force the quick couplers together.

NOTE: See the loader's operator's manual for auxiliary hydraulic specifications and connection instructions.

NOTE: Attachment is shipped with 8FJX (1/2" Female JIC Swivel) fittings on the ends of the lead hoses.

NOTE: More than one routing may be acceptable depending on the loader. Pick the routing that best suits your loader.

IMPORTANT: Proper hose routing is the responsibility of the owner and/or operator. Pinched or stretched hoses are not covered under warranty.

NOTE: Mounting is now complete and the attachment is ready for operation. Use reverse order of above instructions to dismount the attachment from the loader.

OPERATING INSTRUCTIONS

The landscape rake is designed to be used for the removal of rocks less than 6" in diameter from loose soil. It is recommended that the ground be broken up before using the landscape rake if the soil is very hard and/or compacted.

IMPORTANT: Make sure the work area is free of rocks larger than 6" in diameter, large tree branches, logs, roots, wire, and other items that are either too large for the rake to handle or could wrap around the chain and/or rake bars. Failure to do so may result in damage to the attachment.

1. With the operator in the seat of the loader, the seat belt fastened, and the seat bar lowered (if so equipped), start the engine.
2. Position the loader and attachment in the area to be raked. With the attachment raised slightly off of the ground, activate the loader's continuous flow auxiliary hydraulics to operate the rake chain. See the loader's operator's manual for auxiliary hydraulic controls.

IMPORTANT: Never use high flow hydraulics or operate the landscape rake at excessive speeds, as this can cause excessive wear or damage. Maximum engine RPM is not required to run the landscape rake efficiently. Operator experience will help determine the best speed at which to run the attachment.

3. Lower the loader arms completely and activate the boom float function (see the loader's operator's manual for boom float controls). Tilt the attachment forward until the unit is resting on the front skid shoes.

NOTE: The front skid shoes control the penetration depth of the rake. To adjust, refer to the instructions on page 13 in the "Routine Maintenance" section of this manual.

4. Slowly drive the loader backward to rake up rocks and debris from the soil.

NOTE: The landscape rake is designed to operate while the loader moves backwards. The attachment will not rake effectively while driving the loader forward.

NOTE: Depending on soil conditions, multiple passes may be required to achieve the desired finish.

OPERATING INSTRUCTIONS

Dumping Material

When rocks and material begin to fall out of the bucket and against the screen, the bucket is full.

To empty:

1. Deactivate hydraulic flow to the attachment, and lift the attachment slightly off of the ground.
2. Keeping the load low, carry the attachment to the dumping site.
3. Activate the auxiliary hydraulic flow in the REVERSE direction of normal operation to operate tooth bars in reverse to help clean debris from bucket
4. Raise the loader arms and tilt the attachment forward to dump material from the bucket.

⚠ WARNING To avoid serious injury or death due to tipover, NEVER lift a loaded landscape rake more than 3 feet off of the ground.

5. Once the bucket has been emptied, lower the attachment back to the ground.
6. Carrying the attachment low to the ground, return to the raking site and resume raking operation.

ROUTINE MAINTENANCE

⚠ WARNING

Lower the attachment to rest flat on the ground, shut down the engine, relieve the hydraulic pressure to the attachment, set the park brake, and wait for all motion to stop before leaving the operator's seat to perform service of any kind.

It is the operator's responsibility to make daily inspections of the loader and attachment for damage, loose bolts, fluid leaks, or anything else that could cause a potential service or safety problem. Preventive maintenance is the easiest and least expensive type of maintenance.

IMPORTANT: Bolts can loosen after initial usage. After the first hour of operation check all bolts.

LUBRICATION

Lubrication Legend



Multipurpose spray lube



Multipurpose grease lube



Multipurpose oil lube



Intervals at which lubrication is required

Use No. 2 lithium base gun grease when lubricating all attachment grease fittings.

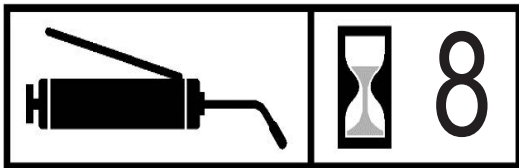

Grease both bucket pivot points (A) after **8 hours** of operation.

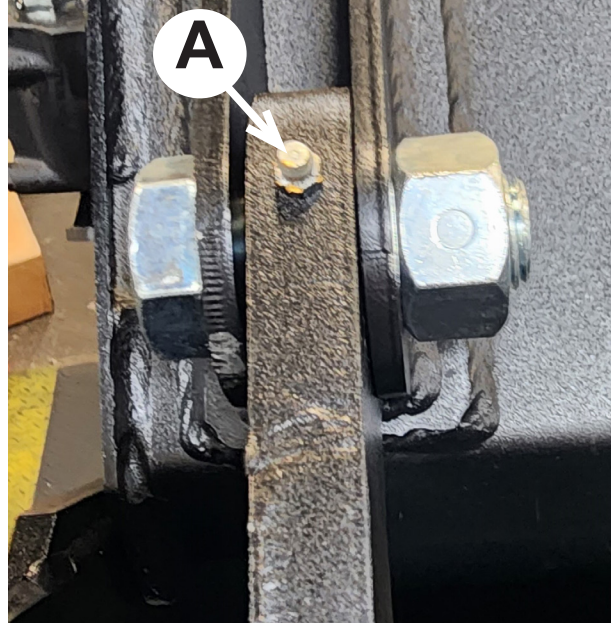

ROUTINE MAINTENANCE

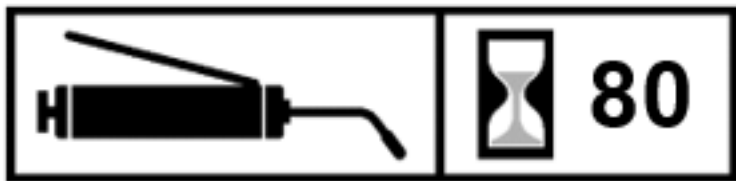

Grease the (4) bearing zerks [B] every **80 hours** of operation.

Important: Do not over-grease bearings. Only add **two pumps** of grease every greasing interval.

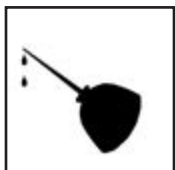
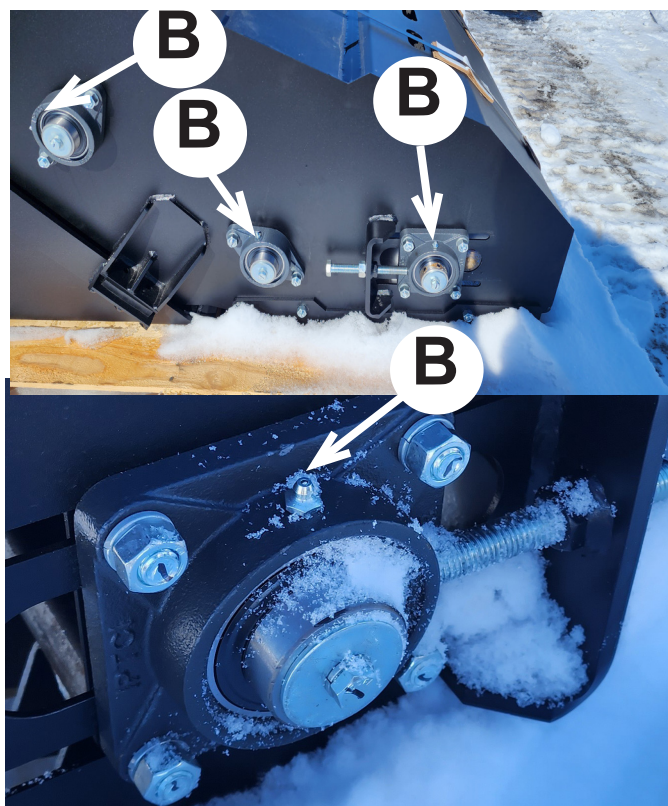

Use clean engine oil to lubricate the rake bar chains [C] before storing the attachment for an extended period of time (more than 6 weeks).

⚠ WARNING Before working underneath attachment, use blocks or jack stands to support the open landscape rake.

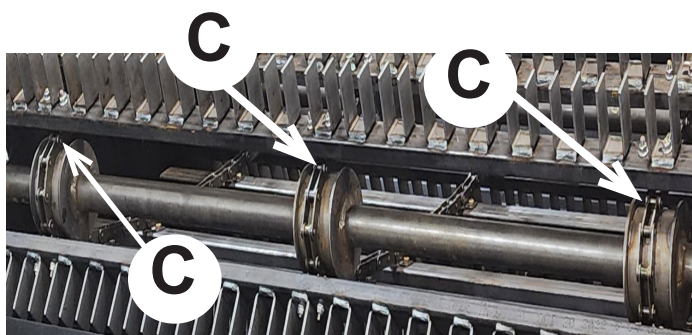

ROUTINE MAINTENANCE

Skid Shoe Adjustment

The depth of rake penetration can be adjusted using the skid shoes. To adjust depth:

1. Position the attachment with the front slightly elevated by placing blocks underneath the bucket of the closed attachment.
2. Remove the carriage bolts and lock nuts securing each skid shoe.
3. Align the skid shoes with the appropriate holes for the desired penetration depth, and reinstall the carriage bolts and lock nuts.

NOTE: Both skid shoes must be positioned at the same depth for level operation of the attachment.

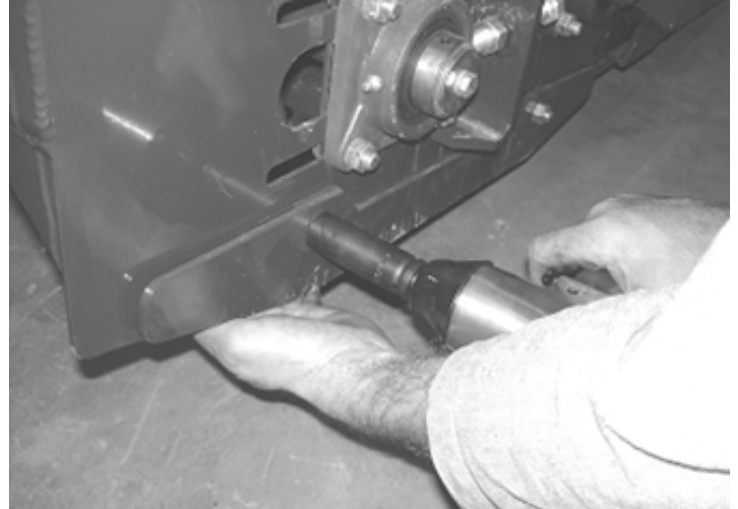

ROUTINE MAINTENANCE

Rake Bar Chain Adjustment

IMPORTANT: Check rake bar chain tension after first hour of operation.

1. Loosen the bolts securing the square flange bearings on each side of the attachment.
2. Loosen the zinc locking nut from from the tightener bracket. Using a wrench tighten the tensioner bolt only until chains are taut.

IMPORTANT: Do not overtighten roller chains. Tighten only enough to remove slack.

IMPORTANT: To prevent damage to the attachment, measure both bearings to make sure they are adjusted evenly.

3. Tighten all bolts securing the square flange bearings on each side of the attachment.

Note: Brand new chains should have the tensioner bolt tightened until roughly 3 inches is left outside of the bracket.

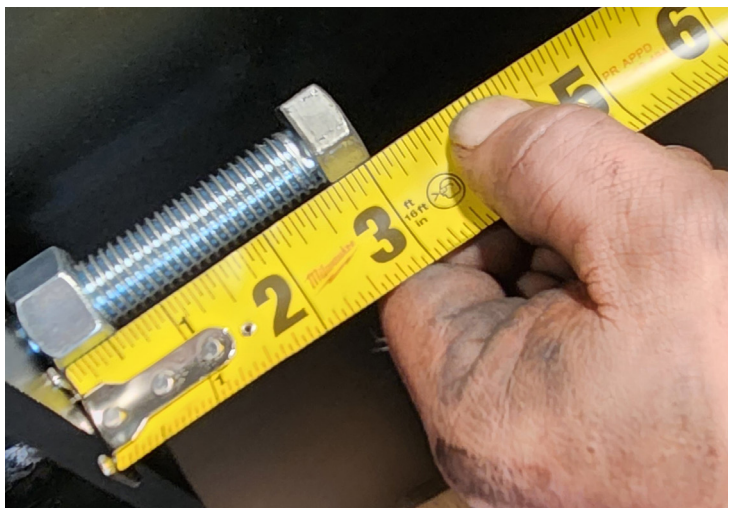

ROUTINE MAINTENANCE

Rake Bar Replacement

NOTE: For additional wear life, once one side of the rake bar is worn, the bar can be turned around and the other side may be used before the bar needs to be replaced.

1. Position the attachment on a flat, level surface.
2. Open the attachment using a lift hoist, hooking onto the top front of the rake body.



⚠ WARNING Before working underneath attachment, use blocks or jack stands to support open landscape rake.

3. Remove the bolts and nuts securing the rake bar in place, and remove the rake bar.
4. Align the new rake bar with the rake chain holes, and reinstall the bolts and nuts to secure the rake bar in place.
5. Tighten all hardware to the proper torque (see “Bolt Torque information” on page 16).
6. Repeat for each rake bar to be replaced



PARTS INFORMATION

ITEM	QTY	PART NO.	DESCRIPTION	NOTES
17	1	318430	CUTTING EDGE B 74 DB	
18	7	22664	BOLT PLOW 5/8 X 1-3/4 NC GR 5	
19	2	13463	BOLT HEX 1 X 2-1/2 NC GR 5	
21	4	200066	BOLT CARRIAGE 1/2 X 1-1/4 NC GR 5	
22	11	37214	NUT REV LOCK 1/2 NC GR 5 Z	
31	9	36314	NUT HEX FULL 5/8 NC GR 5 Z	
42	1	103396	MOTOR HYD 24 CID 2K STD	
55	4	318232	PLATE SKID PAINTED	
56	2	318245	PLATE BACKING PAINTED	
58	2	13325	BOLT TAP 5/8 X 6 NC GR 5	
63	7	33630	WASHER SPLIT LOCK 5/8	
77	2	37219	NUT REV LOCK 1 NC GR 5 Z	
81	1	400200	MOTOR MOUNT W/A	
84	2	13210	BOLT HEX 1/2 X 1-3/4 NC GR 5	
87	5	13207	BOLT HEX 1/2 X 1-1/4 NC GR 5	
92	1	350432	COUPLER LSR 1.25 X 1.75 X 5 Z	
95	2	350440	BUMPER RUBBER 4 X 1.25 X .75	
96	1	350443	BODY RAKE 72 W/A	
98	4	33004	WASHER FLAT USS 1/4	
100	1	350449	BUCKET LSR 72 W/A V2	
102	4	13007	BOLT HEX 1/4 X 1-1/4 NC GR 5	
106	1	350452	WASHER PLATE .39 X 1.70 X .25 Z	
107	1	13107	BOLT HEX 3/8 X 1-1/4 NC GR 5	
108	8	36302	NUT HEX FULL 1/4 NC GR5 Z	

PARTS INFORMATION

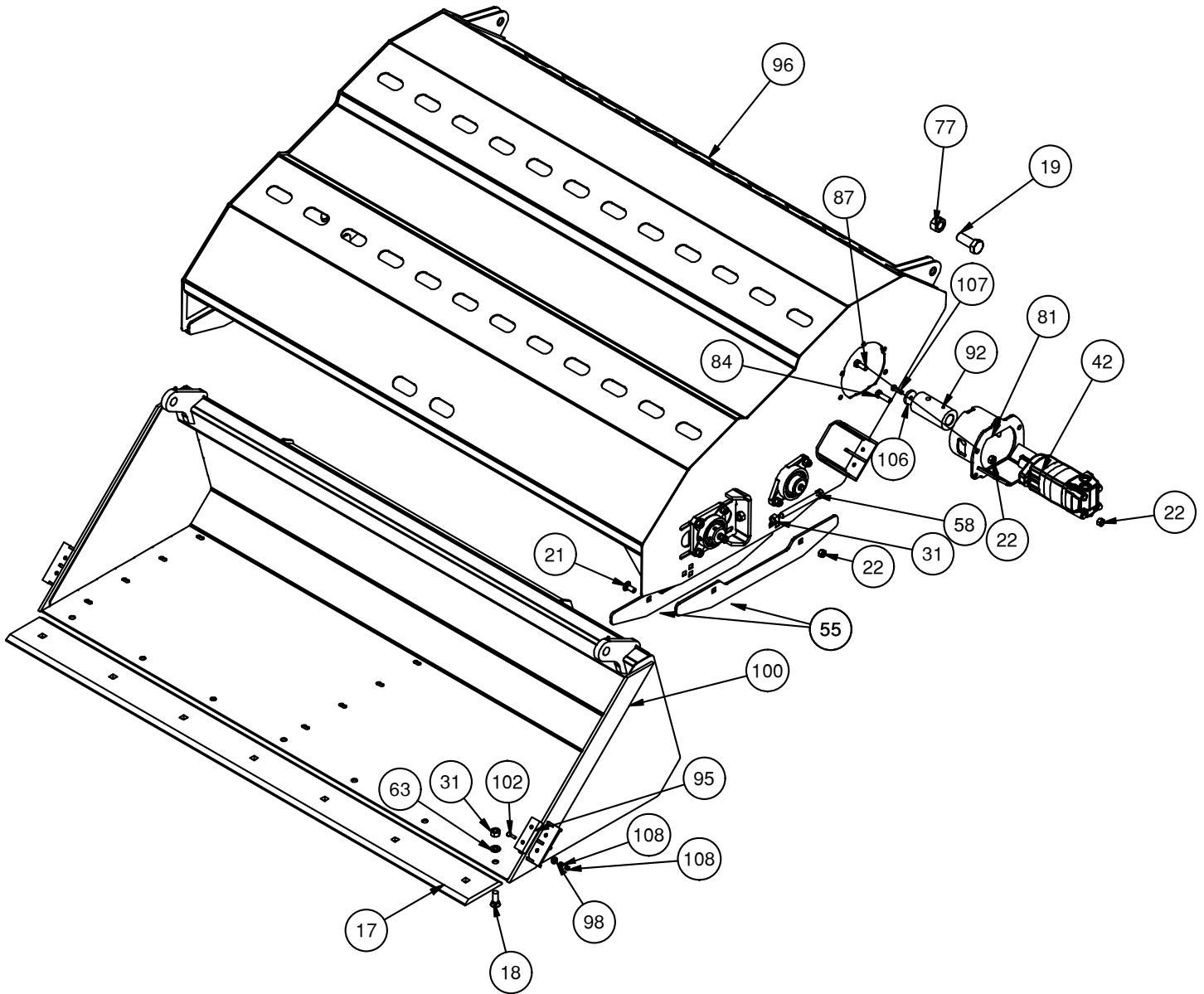

PARTS INFORMATION

ITEM	QTY	PART NO.	DESCRIPTION	NOTES
42	1	103396	MOTOR HYD 24 CID 2K STD	
86	2	201283	HOSE END 8-10MB	
101	2	201280	HOSE END 8-8FJX	
104	2	350456	HOSE 5/8" x 96" 10MB-12FJX	REPLACED 401130 (FOR 12MJ COUPLERS)
	2	401130	HOSE 1/2 X 96 10MB-8FJX	REPLACED BY 350456 (FOR 8MJ COUPLERS)

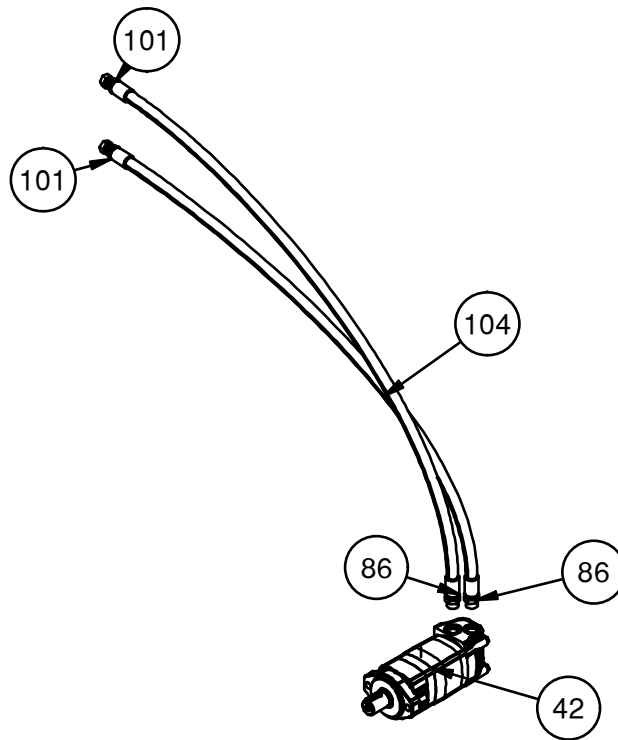

PARTS INFORMATION

ITEM	QTY	PART NO.	DESCRIPTION	NOTES
3	2	319085	BRG 1 1/2 4-B FLG B-TYPE	
4	3	318233	BRG 1-1/2 2-B B-TYPE	
22	1	37214	NUT REV LOCK 1/2 NC GR 5 Z	
23	14	36310	NUT HEX FULL 1/2 NC GR5 Z	
24	14	33626	WASHER SPLIT LOCK 1/2"	
26	5	13105	BOLT HEX 3/8 X 1 NC GR 5	
28	5	103880	WASHER SPLIT LOCK 3/8"	
36	12	318203	TOOTH BAR 72 W/A	
56	2	318245	PLATE BACKING PAINTED	
60	5	202830	WASHER PLATE .41 X 1.75 X .13	
62	14	318277	BOLT CARR 1/2 X 1-1/2 NC SHORT NECK	
67	72	15060	BOLT HEX 5/16 X 1-3/4 NC GR8 YZ	
69	72	0167008	NUT FLG TOP-LOCK 5/16 NC GR8	
92	1	350432	COUPLER LSR 1.25 X 1.75 X 5 Z	
94	1	350435	SHAFT LANDSCAPE RAKE DRIVE W/A	
97	3	318270	CHAIN CONVERYOR #2060H 48P	
103	1	13217	BOLT HEX 1/2 X 3-1/2 NC GR 5	
105	2	318202	SHAFT IDLE 72 W/A	
109	1	25437	SET SCREW 5/16-18 X 3/8	

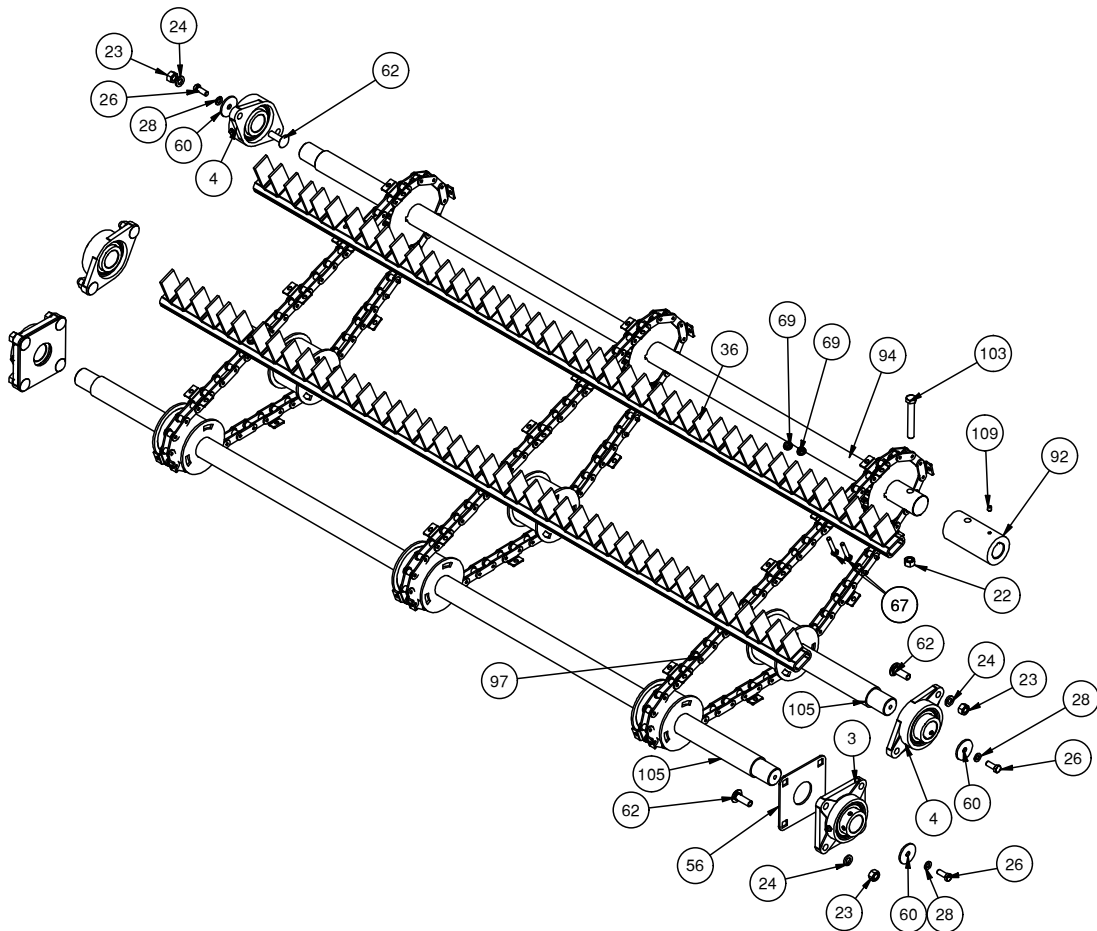

TORQUE INFORMATION

Torque-Tension Relationships for SAE J429 Grade Bolts

Nominal Thread Size	SAE J429 Grade 2			SAE J429 Grade 5			SAE J429 Grade 8		
	Clamp Load (lbs)	Tightening Torque		Clamp Load (lbs)	Tightening Torque		Clamp Load (lbs)	Tightening Torque	
		K = .15	K = .20		K = .15	K = .20		K = .15	K = .20
Unified Coarse Thread Series									
1/4-20	1,300	49 in-lbs	65 in-lbs	2,000	75 in-lbs	100 in-lbs	2,850	107 in-lbs	143 in-lbs
5/16-18	2,150	101	134	3,350	157	210	4700	220	305
3/8-16	3,200	15 ft-lbs	20 ft-lbs	4,950	23 ft-lbs	31 ft-lbs	6,950	32.5 ft-lbs	44 ft-lbs
7/16-14	4,400	24	30	6,800	37	50	9,600	53	70
1/2-13	5,850	36.5	49	9,050	57	75	12,800	80	107
9/16-12	7,500	53	70	11,600	82	109	16,400	115	154
5/8-11	9,300	73	97	14,500	113	151	20,300	159	211
3/4-10	13,800	129	173	21,300	200	266	30,100	282	376
7/8-9	11,425	125	166	29,435	321	430	41,550	454	606
1-8	15,000	187.5	250	38,600	482.5	640	54,540	680	900
Unified Fine Thread Series									
1/4-28	1,500	55 in-lbs	75 in-lbs	2,300	85 in-lbs	115 in-lbs	3,250	120 in-lbs	163 in-lbs
5/16-24	2,400	112	150	3,700	173	230	5,200	245	325
3/8-24	3,600	17 ft-lbs	22.5 ft-lbs	5,600	26 ft-lbs	35 ft-lbs	7,900	37 ft-lbs	50 ft-lbs
7/16-20	4,900	27	36	7,550	42	55	10,700	59	78
1/2-20	6,600	41	55	10,200	64	85	14,400	90	120
9/16-18	8,400	59	79	13,000	92	122	18,300	129	172
5/8-18	10,600	83	110	16,300	128	170	23,000	180	240
3/4-16	15,400	144	193	23,800	223	298	33,600	315	420
7/8-14	12,610	138	184	32,480	355	473	45,855	500	668
1-12	16,410	205	273	42,270	528	704	59,670	745	995

Clamp load estimated as 75% of proof load for specified bolts.

Torque values for 1/4 and 5/16 inch series are in inch-pounds. All other torque values are in foot-pounds.

Torque values calculated from formula $T = KDF$

where: K=0.15 for "lubricated" conditions

K=0.20 for "dry" conditions

GENERAL SPECS

Model	72
Working Width	72"
Overall Height	26.543"
Rake Bar Quantity	12
Quantity of Teeth per Unit	252
Cutting Edge	5/8" x 6" Reversible Bolt-On
Hydraulic Motor Flow Range	13-25 GPM
Skid Shoes	3-Position Adjustable
Tooth Construction	7GA Steel
Operating Weight	1,360 LBS

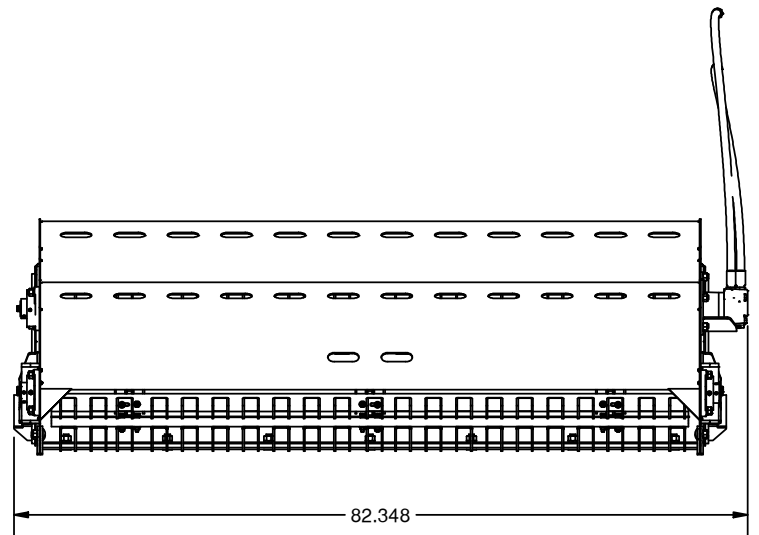
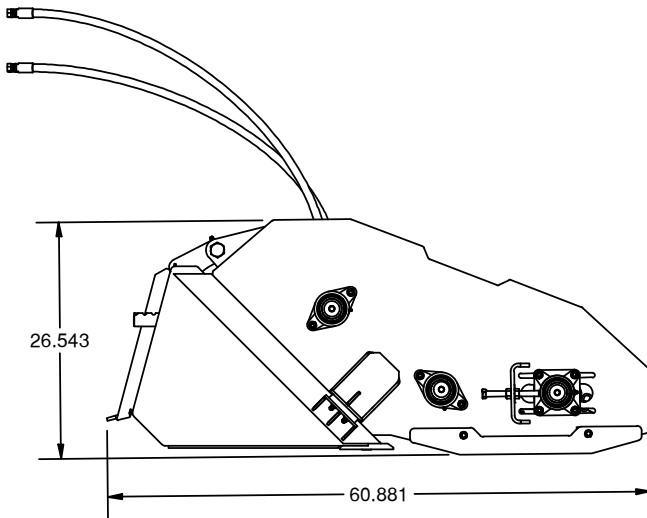



LIMITED WARRANTY

Quick Attach Attachments, LLC warrants each new machine manufactured by us to be free from defects in material and workmanship for a period of twenty-four (24) months from date of delivery to the original purchaser.

Our obligation under this warranty is to replace free of charge, at our factory or Direct Outlet locations, any part proven defective within the stated warranty time limit.

All parts must be returned freight prepaid and adequately packaged to prevent damage in transit.

This warranty does not cover:

1. New products which have been operated in excess of rated capacities or negligence
2. Misuse, abuse, accidents or damage due to improperly routed hoses
3. Machines which have been altered, modified or repaired in any manner not authorized by our company
4. Previously owned equipment
5. Any ground engaging tools in which natural wear is involved, i.e. tooth tips, cutting teeth, etc
6. Normal maintenance
7. Fork tines
8. Hydraulic motors that have been disassembled in any manner

In no event will the Sales Representative, Direct Outlet, Quick Attach Attachments, LLC, or any other company affiliated with it or them be liable for incidental or consequential damages or injuries, including but not limited to the loss of profit, rental or substitute equipment or other commercial loss. Purchaser's sole and exclusive remedy being as provided here in above.

Quick Attach Attachments, LLC must receive immediate notification of defect and no allowance will be made for repairs without our consent or approval.

This warranty is in lieu of all other warranties, express or implied by law or otherwise, and there is no warranty of merchantability or fitness purpose.

No agent, employee, or representative of Quick Attach Attachments, LLC has any authority to bind Quick Attach Attachments, LLC to any warranty except as specifically set forth herein. Any of these limitations excluded by local law shall be deemed deleted from this warranty; all other terms apply.

This warranty may not be enlarged or modified in any manner except in writing signed by an executive officer of Quick Attach Attachments, LLC to improve its products whenever it is possible and practical to do so. Quick Attach Attachments, LLC reserves the right to make changes and or add improvements at any time without incurring any obligation to make such changes or add such improvements to products previously sold.

Quick Attach Attachments, LLC
P.O. Box 128 Alexandria, MN 56308
Phone (320) 759-1551
Fax (320) 759-1590

